

Hitachi Storage Plug-in for VMware vCenter

v04.11.0

User's Guide

This guide provides information about installing, configuring, and managing Hitachi Storage Plug-in for VMware vCenter.

© 2024 Hitachi Vantara, Ltd. All rights reserved.

No part of this publication may be reproduced or transmitted in any form or by any means, electronic or mechanical, including copying and recording, or stored in a database or retrieval system for commercial purposes without the express written permission of Hitachi, Ltd., or Hitachi Vantara LLC (collectively "Hitachi"). Licensee may make copies of the Materials provided that any such copy is: (i) created as an essential step in utilization of the Software as licensed and is used in no other manner; or (ii) used for archival purposes. Licensee may not make any other copies of the Materials. "Materials" mean text, data, photographs, graphics, audio, video and documents.

Hitachi reserves the right to make changes to this Material at any time without notice and assumes no responsibility for its use. The Materials contain the most current information available at the time of publication.

Some of the features described in the Materials might not be currently available. Refer to the most recent product announcement for information about feature and product availability, or contact Hitachi Vantara LLC at https://support.hitachivantara.com/en_us/contact-us.html.

Notice: Hitachi products and services can be ordered only under the terms and conditions of the applicable Hitachi agreements. The use of Hitachi products is governed by the terms of your agreements with Hitachi Vantara LLC.

By using this software, you agree that you are responsible for:

1. Acquiring the relevant consents as may be required under local privacy laws or otherwise from authorized employees and other individuals; and
2. Verifying that your data continues to be held, retrieved, deleted, or otherwise processed in accordance with relevant laws.

Notice on Export Controls. The technical data and technology inherent in this Document may be subject to U.S. export control laws, including the U.S. Export Administration Act and its associated regulations, and may be subject to export or import regulations in other countries. Reader agrees to comply strictly with all such regulations and acknowledges that Reader has the responsibility to obtain licenses to export, re-export, or import the Document and any Compliant Products.

Hitachi and Lumada are trademarks or registered trademarks of Hitachi, Ltd., in the United States and other countries.

AIX, DB2, DS6000, DS8000, Enterprise Storage Server, eServer, FICON, FlashCopy, GDPS, HyperSwap, IBM, OS/390, PowerHA, PowerPC, S/390, System z9, System z10, Tivoli, z/OS, z9, z10, z13, z14, z15, z16, z/VM, and z/VSE are registered trademarks or trademarks of International Business Machines Corporation.

Active Directory, ActiveX, Bing, Excel, Hyper-V, Internet Explorer, the Internet Explorer logo, Microsoft, Microsoft Edge, the Microsoft corporate logo, the Microsoft Edge logo, MS-DOS, Outlook, PowerPoint, SharePoint, Silverlight, SmartScreen, SQL Server, Visual Basic, Visual C++, Visual Studio, Windows, the Windows logo, Windows Azure, Windows PowerShell, Windows Server, the Windows start button, and Windows Vista are registered trademarks or trademarks of Microsoft Corporation. Microsoft product screen shots are reprinted with permission from Microsoft Corporation.

All other trademarks, service marks, and company names in this document or website are properties of their respective owners.

Copyright and license information for third-party and open source software used in Hitachi Vantara products can be found in the product documentation, at <https://www.hitachivantara.com/en-us/company/legal.html>.

Contents

Preface.....	6
Intended audience.....	6
Product version.....	6
Release notes.....	6
Changes in this revision.....	6
Referenced documents.....	7
Document conventions.....	7
Conventions for storage capacity values.....	9
Accessing product documentation.....	10
Getting help.....	10
Comments.....	10
Chapter 1: Overview of Hitachi Storage Plug-in for VMware vCenter.....	11
Hitachi Storage Plug-in features.....	11
Key terms and concepts.....	11
Chapter 2: System Requirements.....	15
Required system configuration for Hitachi Storage Plug-in.....	15
Hardware requirements.....	17
Software requirements.....	18
Storage system requirements.....	19
Port Requirements	20
Restrictions and considerations	21
Chapter 3: Setting up Hitachi Storage Plug-in.....	25
Installing Hitachi Storage Plug-in.....	25
Deploying a Backend Server.....	25
Setting up SSL certificates.....	26
Running a shell script on the Backend Server (registering the plug-in).....	27
Verifying installation of Hitachi Storage Plug-in.....	28
Upgrading Hitachi Storage Plug-in.....	28
Upgrading Hitachi Storage Plug-in by upgrading its files.....	29
Upgrading files related to the plug-in on the Backend Server.....	30
Upgrading Hitachi Storage Plug-in by deploying a new Backend Server.....	31

Migrating the configuration files from an older version of the Backend Server.....	31
Migrating the IP address of an older version of the Backend Server.....	32
Upgrading the plug-in on the vCenter Server.....	33
Restoring Hitachi Storage Plug-in.....	34
Copying backup files on the Backend Server.....	34
Uninstalling Hitachi Storage Plug-in.....	35
Running a shell script on the Backend Server (unregistering the plug-in)...	35
Deleting the Backend Server.....	36
Verifying uninstallation of Hitachi Storage Plug-in.....	36
Restarting the vSphere Client service in the vCenter Server.....	36
Restarting services on the Backend Server.....	37
Changing network information about the Backend Server.....	37
Changing the configuration files.....	38
Log file.....	38
LUN ID.....	40
Role-Based Access Control.....	41
Setting up Role-Based Access Control.....	42
Disabling the setting for Role-Based Access Control.....	43
Confirming the version of Hitachi Storage Plug-in.....	43
Chapter 4: Using Hitachi Storage Plug-in.....	45
Accessing Hitachi Storage Plug-in.....	45
Adding a storage system.....	45
Adding a block storage system.....	46
Adding VSP One SDS Block.....	47
Adding a VSP One SDS Block.....	47
Removing a storage system.....	48
Refreshing storage system information.....	49
Refreshing all storage systems.....	49
Refreshing selected storage systems.....	50
Provisioning datastores.....	50
Overview of Provision Datastore	51
Creating a datastore.....	51
Creating VMFS datastores	52
Creating LUs/volumes for Raw Device Mapping(RDM).....	54
Cancelling Provision Datastore.....	57
Expanding a datastore.....	57
Deleting datastores	58
Deleting a VMFS datastore/LU/volume.....	59
Deleting an NFS datastore.....	60

Chapter 5: Information Display.....	61
Datastore information.....	61
Host information.....	61
Virtual Machines information.....	61
Chapter 6: Troubleshooting.....	62
Troubleshooting Hitachi Storage Plug-in installation.....	62
Troubleshooting Hitachi Storage Plug-in operational errors.....	62
Troubleshooting storage system errors.....	62
Troubleshooting Hitachi Ops Center API Configuration Manager server errors.....	63
Troubleshooting errors related to the datastore creation function.....	64
Retry of Provision Datastore.....	64
Rollback of Provision Datastore.....	65
Provision Datastore task stops before completing.....	65
Stops while retrying NFS Export Creation.....	66
Stops while creating an NFS datastore.....	66
Troubleshooting errors related to the datastore deletion function.....	66
Retry of Delete Datastore.....	66
Delete Datastore stops before it has completed.....	66
Troubleshooting when attempts to connect to the Backend Server fail.....	67
Chapter 7: Information to collect when a failure occurs.....	68
Collecting log files.....	68
Collecting log files from Hitachi Storage Plug-in.....	68
Collecting vCenter Server Appliance information.....	70
How to collect Hitachi Ops Center API Configuration Manager information.....	70
Collecting Hitachi Ops Center API Configuration Manager maintenance information	71
Collecting storage system information.....	71
Collecting Windows Event Log information.....	71
Collecting Windows system information.....	71
Confirming versions.....	71
Confirming the vCenter Server version.....	71
Confirming the ESXi version.....	72
Checking the browser information about vSphere Client.....	72
Confirming the vSphere Client version.....	72

Preface

This guide explains how to install, configure and use Hitachi Storage Plug-in for VMware vCenter with supported storage systems.

Intended audience

This document is intended for operators of VMware management console (VMware vSphere Client) to verify the configurations of the storage system and perform setting operations (creation of a datastore) using the storage system.

Before reading this document, make sure you are familiar with the use of the VMware vSphere Client.

Product version

This document supports Hitachi Storage Plug-in for VMware vCenter v04.11.0.

Release notes

Read the release notes before installing and using this product. They may contain requirements or restrictions that are not fully described in this document or updates or corrections to this document. Release notes are available on the Hitachi Vantara documentation website: <https://docs.hitachivantara.com>.

Changes in this revision

The following changes have been made to this document:

Descriptions were changed with regard to the change from Hitachi Virtual Storage Software block to VSP One SDS Block.

The following changes were made with regard to v1.14 of VSP One SDS Block:

- Added the fact that the compression function can now be used in VSP One SDS Block.
- Added a description of NVMe over TCP and the operating procedure.

Added descriptions for the VSP One B20 storage system and added operating procedures for the REST API with regard to those descriptions.

Removed descriptions for HNAS and VSP Nx00 NAS module.

Referenced documents

Hitachi documents:

- *Hitachi Ops Center API Configuration Manager REST API Reference Guide*, MK-99CFM000
- *System Administrator Guide*

Storage model	Part number
VSP E590, E790, E990, E1090, E590H, E790H, E1090H VSP F350, F370, F700, F900 VSP G350, G370, G700, G900	MK-97HM85028
VSP F400, F600, F800 VSP G200, G400, G600, G800 VSP N400, N600, N800	MK-94HM8016
Hitachi Virtual Storage Platform 5100, 5200, 5500, 5600 5100H, 5200H, 5500H, 5600H	MK-98RD9009
VSP F1500 VSP G1000, G1500	MK-92RD8016
VSP One B24, B26, B28	MK-23VSP1B009
VSP One SDS Block	MK-91VSSB001

VMware documents:

- VMware vSphere ESXi and vCenter Server 7.0/8.0

Hitachi Vantara Support Connect, <https://knowledge.hitachivantara.com>





Document conventions

This document uses the following typographic conventions:

Convention	Description
Bold	<ul style="list-style-type: none"> Indicates text in a window, including window titles, menus, menu options, buttons, fields, and labels. Example: Click OK. Indicates emphasized words in list items.
<i>Italic</i>	<ul style="list-style-type: none"> Indicates a document title or emphasized words in text. Indicates a variable, which is a placeholder for actual text provided by the user or for output by the system. Example: <pre>pairdisplay -g group</pre> <p>(For exceptions to this convention for variables, see the entry for angle brackets.)</p>
Monospace	Indicates text that is displayed on screen or entered by the user. Example: <code>pairdisplay -g oradb</code>
< > angle brackets	Indicates variables in the following scenarios: <ul style="list-style-type: none"> Variables are not clearly separated from the surrounding text or from other variables. Example: <pre>Status-<report-name><file-version>.csv</pre> Variables in headings.
[] square brackets	Indicates optional values. Example: [a b] indicates that you can choose a, b, or nothing.
{ } braces	Indicates required or expected values. Example: { a b } indicates that you must choose either a or b.
vertical bar	Indicates that you have a choice between two or more options or arguments. Examples: [a b] indicates that you can choose a, b, or nothing. { a b } indicates that you must choose either a or b.

This document uses the following icons to draw attention to information:

Icon	Label	Description
	Note	Calls attention to additional information.

Icon	Label	Description
	Tip	Provides helpful information, guidelines, or suggestions for performing tasks more effectively.
	Important	Highlights information that is essential to the completion of a task.
	Caution	Warns the user of adverse conditions and/or consequences (for example, disruptive operations, data loss, or a system crash).
	CAUTION	Warns the user of a hazardous situation that, if not avoided, could result in major or minor injury.
	WARNING	Warns the user of a hazardous situation which, if not avoided, could result in death or serious injury.

Conventions for storage capacity values

Physical storage capacity values (for example, disk drive capacity) are calculated based on the following values:

Physical capacity unit	Value
1 kilobyte (KB)	1,000 (10 ³) bytes
1 megabyte (MB)	1,000 KB or 1,000 ² bytes
1 gigabyte (GB)	1,000 MB or 1,000 ³ bytes
1 terabyte (TB)	1,000 GB or 1,000 ⁴ bytes
1 petabyte (PB)	1,000 TB or 1,000 ⁵ bytes
1 exabyte (EB)	1,000 PB or 1,000 ⁶ bytes

Logical capacity values (for example, logical device capacity, cache memory capacity) are calculated based on the following values:

Logical capacity unit	Value
1 block	512 bytes
1 cylinder	Mainframe: 870 KB

Logical capacity unit	Value
	Open-systems: <ul style="list-style-type: none"> ▪ OPEN-V: 960 KB ▪ Others: 720 KB
1 KB	1,024 (2 ¹⁰) bytes
1 MB	1,024 KB or 1,024 ² bytes
1 GB	1,024 MB or 1,024 ³ bytes
1 TB	1,024 GB or 1,024 ⁴ bytes
1 PB	1,024 TB or 1,024 ⁵ bytes
1 EB	1,024 PB or 1,024 ⁶ bytes

Accessing product documentation

Product user documentation is available on: <https://docs.hitachivantara.com>. Check this site for the most current documentation, including important updates that may have been made after the release of the product.

Getting help

The [Hitachi Vantara Support Website](https://support.hitachivantara.com) is the destination for technical support of products and solutions sold by Hitachi Vantara. To contact technical support, log on to the Hitachi Vantara Support Website for contact information: https://support.hitachivantara.com/en_us/contact-us.html.

[Hitachi Vantara Community](https://community.hitachivantara.com) is a global online community for Hitachi Vantara customers, partners, independent software vendors, employees, and prospects. It is the destination to get answers, discover insights, and make connections. **Join the conversation today!** Go to community.hitachivantara.com, register, and complete your profile.

Comments

Please send comments to doc.comments@hitachivantara.com. Include the document title and number, including the revision level (for example, -07), and refer to specific sections and paragraphs whenever possible. All comments become the property of Hitachi Vantara LLC.

Thank you!

Chapter 1: Overview of Hitachi Storage Plug-in for VMware vCenter

Hitachi Storage Plug-in for VMware vCenter (referred to as Hitachi Storage Plug-in in this document) integrates Hitachi storage system information and provisioning operations into the vSphere Client.

This integration allows VMware product administrators to perform storage provisioning operations from within the VMware user interface, which offers greater convenience than switching between VMware and Hitachi management software to perform common operations involving both.

Hitachi Storage Plug-in features

Hitachi Storage Plug-in provides the following features.

View

The View function displays the storage system information registered in Hitachi Storage Plug-in, the datastore on the ESXi host using the storage system, and virtual machine information.

Provision Datastore

The Provision Datastore function creates an LU/volume used as a datastore for a Virtual Machine File System (VMFS), a Network File System (NFS), and also for Raw Device Mapping objects (RDMs) by a storage system registered in Hitachi Storage Plug-in.

Delete Datastore

The Delete Datastore function removes datastores created using Hitachi Storage Plug-in and the LUs or volumes of storage systems corresponding to a datastore. This feature does not support datastores and LUs/volumes created without using Hitachi Storage Plug-in.

Key terms and concepts

The term vSphere is a collective name for the VMware-based virtual environment, which includes the VMware vSphere software, VMware vCenter Server software, VMware ESXi clusters and hosts managed by the vCenter Server, and the virtual machines (VMs) and vApps hosted on those ESXi clusters.

For more information, refer to VMware documentation (<https://www.vmware.com/support/pubs/>).

Term	Description
Compute node	A node that the application of the user operates and instructs input / output of user data to the storage node.
Datastore	Virtual area used to store a virtual machine image on ESXi. The actual area is created on a local disk or external storage system.
HDP	Hitachi Dynamic Provisioning. An optional function of the storage system to reduce complicated design. A large volume of virtual capacity eliminates reliance on device capacity.
Virtual storage machine (VSM)	The unit that is used to manage virtualized storage system resources.
Hitachi Ops Center	Storage management software suite, supporting storage resource operation in Enterprise environments.
Hitachi Ops Center API Configuration Manager	Software included in Hitachi Ops Center. Hitachi Ops Center API Configuration Manager REST API provides the Web API, which follows the principles of Representational State Transfer (REST), for getting information about Hitachi storage systems or changing the configuration of Hitachi storage systems.
Host Group	Host groups represent storage system LU/volume masking configurations, which allow a set of HBA ports to access a set of LUs/volumes.
RDM	Raw Device Mappings are VMware configuration objects which allow VMs to directly access LUs/volumes.
Storage node	Physical server to which the CPU, memory, and drives that comprise VSP One SDS Block are assigned. Alternatively, this term refers to a process group of VSP One SDS Block software running on storage nodes.
VPS	An acronym for Virtual Private Storage. This is a virtual storage system logically separated from a VSP One SDS Block storage system.
System administrator	The user who manages an entire VSP One SDS Block cluster.
VPS administrator	A user who manages an individual VPS.
NVMe	Non-Volatile Memory Express is a method for connecting and transferring data between hosts and a storage system. NVMe is designed for use in high-speed storage media with non-volatile memory, such as flash-memory devices. High-speed storage media with non-volatile memory provides low latency, less CPU usage, and high performance, and usually serves as an alternative to SCSI storage.

Term	Description
NVMe over TCP	Technology that uses the TCP protocol to enable NVMe communication.
Host NQN	Host NVMe Qualified Name is a qualified name used to identify a host in a particular context.

Chapter 2: System Requirements

Required system configuration for Hitachi Storage Plug-in

A system that uses Hitachi Storage Plug-in to manage storage systems consists of the following components:

- Hitachi Storage Plug-in
 - Plug-in

Hitachi Storage Plug-in runs on the Backend Server and allows users to view and perform operations on the storage system and datastore information in vSphere Client over a network. When the installation shell script is run on the Backend Server, the Hitachi Storage Plug-in information is registered in vCenter Server as a plug-in.
 - Backend Server

The Backend Server is a virtual appliance (virtual machine) that must be deployed on a supported hypervisor infrastructure such as the ESXi server. The Backend Server enables the communication between Hitachi Storage Plug-in and the Hitachi Ops Center API Configuration Manager server to perform provisioning and monitoring operations on the storage systems.

You can deploy the Backend Server to an existing ESXi server or to a newly deployed ESXi server.
- Depending on the storage system, you need one of the following software products for managing storage systems:
 - Hitachi Ops Center API Configuration Manager

When you register a storage system in Hitachi Ops Center API Configuration Manager, enable the settings for receiving configuration change notifications from the storage system.

The following example shows a typical system configuration that includes Hitachi Storage Plug-in.

- Hitachi Storage Plug-in components require access to storage systems using TCP/IP.
- ESXi must have Fibre Channel or TCP/IP connectivity to storage systems, for details, see [Storage system requirements \(on page 19\)](#).

Example configuration for a block storage system

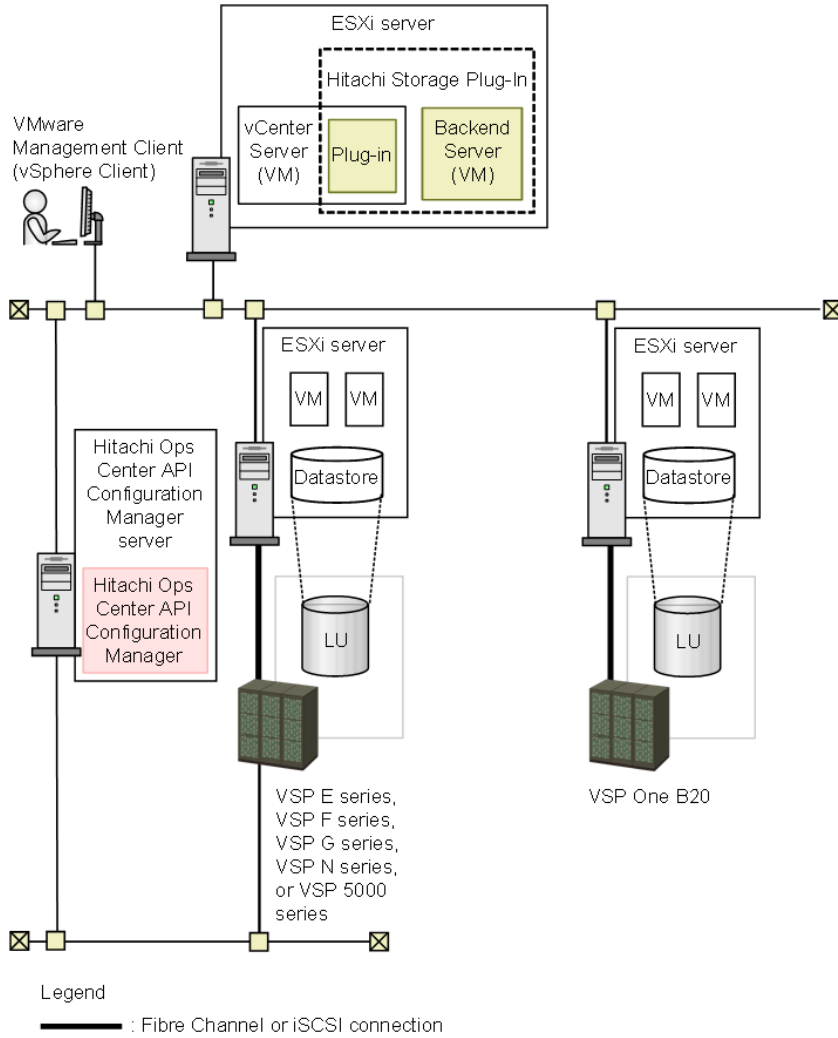

Example configuration for a VSP One SDS Block storage system

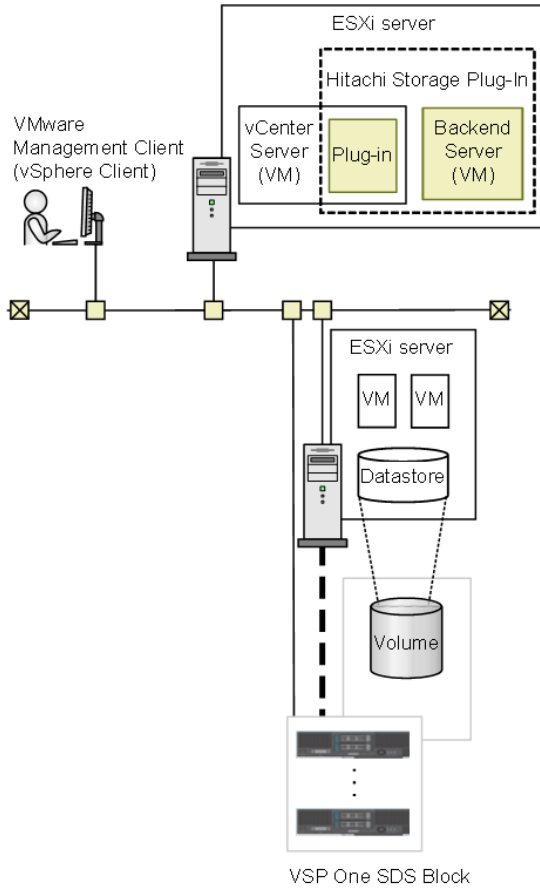

Legend
 - - - : Fibre Channel, iSCSI, or NVMe over TCP connection

Hardware requirements

Backend Server

Item	Requirements	Whether the setting is changeable at deployment
Name of the virtual machine	HitachiStoragePlugin_<version>-00 (default)	Yes
OS	Oracle Linux 9.0 (64-bit)	No
CPU	vCPU (4)	No
Memory	8 GB	No

Item	Requirements	Whether the setting is changeable at deployment
HDD free space	50 GB	No

Software requirements



Caution: Install vSphere Client before installing Hitachi Storage Plug-in.

Software	Version
VMware vCenter Server	<p>One of the following is required:</p> <ul style="list-style-type: none"> ▪ VMware vCenter Server Appliance 7.0 ▪ VMware vCenter Server Appliance 7.0 (Update 1) ▪ VMware vCenter Server Appliance 7.0 (Update 2) ▪ VMware vCenter Server Appliance 7.0 (Update 3) ▪ VMware vCenter Server Appliance 8.0 ▪ VMware vCenter Server Appliance 8.0 (Update 1) ▪ VMware vCenter Server Appliance 8.0 (Update 2) <p> Tip: The vSphere Client is included with the VMware vCenter Server.</p>
VMware ESXi	<p>One of the following is required:</p> <ul style="list-style-type: none"> ▪ VMware ESXi 7.0 ▪ VMware ESXi 7.0 (Update 1) ▪ VMware ESXi 7.0 (Update 2) ▪ VMware ESXi 7.0 (Update 3) ▪ VMware ESXi 8.0 ▪ VMware ESXi 8.0 (Update 1) ▪ VMware ESXi 8.0 (Update 2)

Software	Version
Hitachi Ops Center API Configuration Manager (Hitachi Ops Center Component)	Storage systems and compatible versions: <ul style="list-style-type: none"> ▪ VSP E590, E790: 10.5.1 or later ▪ VSP E990: 10.1.0 or later ▪ VSP E1090: 10.8.0 or later ▪ VSP E590H, E790H: 10.7.0 or later ▪ VSP E1090H: 10.8.0 or later ▪ VSP F350, F370, F700, F900: 8.6.0 or later ▪ VSP G350, G370, G700, G900: 8.6.0 or later ▪ VSP F400, F600, F800: 8.6.2 or later ▪ VSP G200, G400, G600, G800: 8.6.2 or later ▪ VSP N400, N600, N800: 8.6.4 or later ▪ VSP 5100, 5500, 5100H, 5500H: 10.0.0 or later ▪ VSP 5200, 5600, 5200H, 5600H: 10.8.0 or later ▪ VSP F1500: 8.6.2 or later ▪ VSP G1500: 8.6.2 or later ▪ VSP G1000: 8.6.2 or later
Microsoft Windows: <ul style="list-style-type: none"> ▪ Mozilla Firefox ▪ Google Chrome ▪ Microsoft Edge (Only in an environment in which VMware vCenter Server Appliance 7.0 or later is installed) Mac OS: <ul style="list-style-type: none"> ▪ Mozilla Firefox ▪ Google Chrome 	We recommend using the latest version.

Storage system requirements

Storage system	Firmware/Software version	Interface / Host port
VSP E590, E790	93-03-21 or later	Fibre Channel, iSCSI

Storage system	Firmware/Software version	Interface / Host port
VSP E990	93-02-01 or later	Fibre Channel, iSCSI
VSP E1090	93-06-01 or later	Fibre Channel, iSCSI
VSP E590H, E790H	93-05-02 or later	Fibre Channel, iSCSI
VSP E1090H	93-06-01 or later	Fibre Channel, iSCSI
VSP F350, F370, F700, F900 VSP G350, G370, G700, G900	When Hitachi Ops Center API Configuration Manager 8.6.0 or 8.6.1 is used: 88-01-xx or later When Hitachi Ops Center API Configuration Manager 8.6.2 or later is used: 88-03-01 or later	Fibre Channel, iSCSI
VSP F400, F600, F800 VSP G200, G400, G600, G800	83-05-25 or later	Fibre Channel, iSCSI
VSP N400, N600, N800	83-06-01 or later	Fibre Channel, iSCSI, NAS
VSP 5100, 5500, 5100H, 5500H	90-01-42 or later	Fibre Channel, iSCSI
VSP 5200, 5600, 5200H, 5600H	90-08-01 or later	Fibre Channel, iSCSI
VSP F1500 VSP G1000 VSP G1500	80-06-61 or later	Fibre Channel, iSCSI
VSP One B24, B26, B28	A3-02-21 or later	Fibre Channel, iSCSI
VSP One SDS Block Both the ESXi model and the bare metal model are supported.	01.12.00.xx 01.13.00.xx 01.14.00.xx	Fibre Channel, iSCSI, NVMe over TCP

Port Requirements

The default port numbers used by Hitachi Storage Plug-in are as follows.

Communication Source	Protocol/Port Number	Communication Destination
Backend Server	HTTP: 23450/tcp ¹ HTTPS: 23451/tcp ¹	Hitachi Ops Center API Configuration Manager Server
	HTTP: 80/tcp ¹ HTTPS: 443/tcp ¹	REST API server for VSP One B20
	HTTPS: 443/tcp ¹	REST API server running on VSP One SDS Block
	HTTPS: 443/tcp ²	vCenter Server (SDK)
vCenter Server	HTTPS: 8443/tcp ³	Backend Server
<p>Notes:</p> <ol style="list-style-type: none"> 1. When changing the communication port, run the Add Storage Systems operation to change the port number used for connecting. 2. You can change the communication port when you configure the vCenter Server. The settings are saved in vcenterList.json. For details, see Upgrading files related to the plug-in on the Backend Server (on page 30). 3. You cannot change the communication port. 		

Restrictions and considerations

The following restrictions and considerations apply when using Hitachi Storage Plug-in.

Capacity Saving setting in Provision Datastore

If a dedupe and compression program product is installed on the following storage systems, you can set up Capacity Saving: VSP E590, E790, E990, E1090, E590H, E790H, E1090H storage systems, VSP F350, F370, F700, F900 storage systems, VSP G350, G370, G700, G900 storage systems, VSP 5100, 5200, 5500, 5600, 5100H, 5200H, 5500H, 5600H storage systems, and VSP One B20 storage systems. Only the compression function can be used with VSP One SDS Block. If VPS is used, the setting for VPS volume capacity saving determines whether the compression function can be used. To check whether a dedupe and compression program product is installed, contact your storage system administrator.

RAID level

RAID0/1+0/1/5/6 are supported. VSP Ex00 models, VSP Fx00 models, and VSP Gx00 models support RAID1, RAID5, and RAID6.



Note: Do not use RAID0 in the storage system because it does not have data redundancy.

Registering multiple storage systems that have the same serial number

You cannot register multiple storage systems that have the same serial number in Hitachi Storage Plug-in.

Restrictions of the host group name, iSCSI target name, or NVMe over TCP target name

Host group names, iSCSI target names, or NVMe over TCP target names must not include square brackets ([]).

User role

We recommend that users who use Hitachi Storage Plug-in be assigned the Administrator role for vCenter Server. To create a role that has the minimum permissions necessary to use Hitachi Storage Plug-in, select the check boxes for the following permissions for the role:

- Extension > Register extension
- Extension > Update extension
- Extension > Unregister extension
- Global > Log event
- Host > Configuration > Storage partition configuration
- Tasks > Create task
- Tasks > Update task
- Alarms > Create alarm

**Note:**

- To assign a role to a user or group, select Propagate to children.
- You can also implement Role-Based Access Control for users of Hitachi Storage Plug-in. For details, see [Role-Based Access Control \(on page 41\)](#).

Resource group

Hitachi Storage Plug-in does not support resource group management. If you use Hitachi Storage Plug-in, verify the following:

- Storage users registered with Hitachi Storage Plug-in can view all resource groups. If the user's view of resource groups is limited, Hitachi Storage Plug-in will not operate correctly.
- If the target storage system is a VSM, Hitachi Storage Plug-in can create datastores for a resource group belonging to the VSM.

Security Update of Oracle Linux

If a problem occurs in Oracle Linux, which is preinstalled as the guest OS on the Backend Server, contact Oracle Support. At this time, you might need to purchase support services from Oracle. After the Backend Server is deployed, the Backend Server administrator must install security updates for Oracle Linux. For information about installing security updates, see the documentation related to Oracle Linux.

Do not add or update OSS other than for security updates. Also, do not upgrade Oracle Linux major versions.

When the Backend Server is not running

If communication cannot be established with the Backend Server, as in the following cases, check whether the Backend Server is running normally and whether there are any problems with the network.

- The message "no healthy upstream" appears on each screen of the plug-in.
- Plug-in icons are not displayed.



Note: If communication with the Backend Server are not possible, check the procedure [Troubleshooting when attempts to connect to the Backend Server fail \(on page 67\)](#).

Operations by using Hitachi Storage Plug-in in Linked Mode

If Hitachi Storage Plug-in is installed in Linked Mode on multiple vCenter Servers, to perform operations on resources related to one of the vCenter Servers, use vSphere Client to connect to that specific vCenter Server.

For example, if Hitachi Storage Plug-in is installed on vCenter Server A and vCenter Server B, to perform operations on resources related to vCenter Server A, operate Hitachi Storage Plug-in by using the vSphere Client that is connected to vCenter Server A. The same applies to vCenter Server B.

Inheritance of VSP One SDS Block storage information

If you are upgrading from Hitachi Storage Plug-in version 4.8.0 or earlier to 4.9.0 and then upgrade to 4.9.1 or later, the VSP One SDS Block storage information that can be inherited is only the VSP One SDS Block storage information registered with version 4.8.0 or earlier.

Upgrading Hitachi Storage Plug-in

There are two ways to upgrade Hitachi Storage Plug-in: by updating the files related to the plug-in in the Backend Server environment in use or by deploying a new Backend Server.

If you are upgrading from Hitachi Storage Plug-in version 4.9.2 or earlier (Oracle Linux 7) to version 4.10.0 or later (Oracle Linux 9), you cannot perform the upgrade by updating the files related to the plug-in in the Backend Server environment in use, because Oracle Linux 7 is not supported for version 4.10.0 or later. Perform the upgrade according to the procedure in [Upgrading Hitachi Storage Plug-in by deploying a new Backend Server \(on page 31\)](#).

Hitachi Storage Plug-in role-based access control

- Do not add a user to a vCenter Single Sign-On group if the user's domain is different from the domain of the group to which the user belongs. If such a user is added, the user does not inherit the group's roles.
- In vCenter Server 7.0 (Update 2) and earlier environments, do not add Active Directory users to Active Directory groups. If such a user is added, the user does not inherit the roles of the group configured with role-based access control.
- If a user is located in a nested group in vCenter Single Sign-On, the user inherits the roles set for the group immediately above the hierarchical level in which the user is located.

vCenter Single Sign-On (SSO) settings

For vCenter Single Sign-On identity sources, only Active Directory is available. Domain aliases are not supported.

Chapter 3: Setting up Hitachi Storage Plug-in

Install Hitachi Storage Plug-in for VMware vCenter by deploying the Backend Server, running the shell script, and customizing configuration files.

Installing Hitachi Storage Plug-in

Install Hitachi Storage Plug-in by performing the following procedures:

1. [Deploying a Backend Server \(on page 25\)](#)
2. [Setting up SSL certificates \(on page 26\)](#)
Perform this step as needed.
3. [Running a shell script on the Backend Server \(registering the plug-in\) \(on page 27\)](#)
4. [Verifying installation of Hitachi Storage Plug-in \(on page 28\)](#)

Before installing Hitachi Storage Plug-in, set up the vSphere environment and Hitachi Ops Center API Configuration Manager.

Deploying a Backend Server

Deploy the Backend Server by using the distributed OVA file.

Before you begin

Obtain the following network information about the Backend Server:

- IP address
- Gateway
- Netmask

Procedure

1. Run **Deploy OVF Template** on the vSphere Client to deploy the `HitachiStoragePlugin_<version>-00.ova` file.
2. In the dialog box for deploying the OVF template, enter the network information about the Backend Server in IPv4 format. In addition, enter the password of the root user for the Backend Server.
3. After the OVF template is deployed, turn on the power of the Backend Server.

Setting up SSL certificates

Hitachi Storage Plug-in comes with a self-signed certificate, but if you need stronger security, configure settings to use a server certificate (CRT) issued by a certificate authority.

Before you begin

- Send a certificate signing request (CSR) to the certificate authority to obtain a server certificate.
- Make sure that the secret key (`server.key` in this procedure) is stored in `/usr/local/hitachi-storage-plugin/jetty/conf`.

Procedure

1. Store the server certificate issued by the certificate authority in the same directory as the secret key.
2. Stop the Jetty and the Plugin Server services.

```
systemctl stop jetty_sp
systemctl stop plugin-server_sp
```

3. Go to the location where you stored the server certificate in step 1.

```
cd /usr/local/hitachi-storage-plugin/jetty/conf
```

4. To create a keystore, convert the server certificate into a certificate in PKCS12 format. The following is an example where the server certificate is the `ca_server.crt` file.

```
openssl pkcs12 -export -in ca_server.crt -inkey server.key -out server.p12 -name
StoragePluginServerCertificate -password pass:changeit
```

5. Back up the `keystore.jks` file, which is the existing keystore.

```
mv keystore.jks keystore.jks.old
```

6. Create a keystore for the Jetty service.

```
keytool -importkeystore -srckeystore server.p12 -srcstoretype PKCS12 -
srcstorepass changeit -destkeystore keystore.jks -deststoretype PKCS12 -
deststorepass changeit -destkeypass changeit -alias
StoragePluginServerCertificate
```

7. Change the owner and group of the keystore.

```
chown jetty:jetty keystore.jks
```

8. Start the Jetty and the Plugin Server services.

```
systemctl start jetty_sp
systemctl start plugin-server_sp
```

9. Perform the following procedures to re-register Hitachi Storage Plug-in, and then verify that the SSL certificate is configured.
 - a. Referring to [Running a shell script on the Backend Server \(unregistering the plug-in\) \(on page 35\)](#), unregister Hitachi Storage Plug-in from vCenter Server.
 - b. Referring to [Restarting the vSphere Client service in the vCenter Server \(on page 36\)](#), restart the vSphere Client service.
 - c. Referring to [Running a shell script on the Backend Server \(registering the plug-in\) \(on page 27\)](#), register Hitachi Storage Plug-in in vCenter Server.

Running a shell script on the Backend Server (registering the plug-in)

Run the shell script to trigger the installation of Hitachi Storage Plug-in from the Backend Server. This process pushes the plug-in binary from the Backend Server to the vCenter Server where the plug-in is registered.

Before you begin

Obtain the following information:

- The IP address, user name, and password of the vCenter Server
- The password of the vCenter Server Appliance root user

The vCenter Server user account must have the Administrator role for vCenter Server.

Configure the BASH shell settings:

Configure the BASH shell settings for vCenter Server as explained in VMware product documentation (<https://kb.vmware.com/s/article/2100508>).

Procedure

1. Log in to the Backend Server as the root user.
Enter the root user password that was set in [Deploying a Backend Server \(on page 25\)](#).
2. Run the following shell script.

```
/usr/local/hitachi-storage-plugin/StoragePluginforVMwarevCenter.sh <IP-address-of-vCenter-Server> <user-name-of-the-vCenter-Server> <password-of-the-vCenter-Server> <password-of-the-vCenter-Server-Appliance-root-user> registration
```

If no default domain is set for the vCenter Server, specify a domain by adding the domain name to `<user-name-of-the-vCenter-Server>` (for example, `administrator@vsphere.local`).

If the password includes an exclamation point (!) followed by other characters, enclose the password in single quotation marks when you run the shell script.

Example: `'pass!word'`



Note: If you use Hitachi Storage Plug-in on multiple vCenter Servers, including in Linked Mode, you need to register Hitachi Storage Plug-in for each vCenter Server. You can use the plug-in functionality only with vCenter Servers for which Hitachi Storage Plug-in is registered.

Verifying installation of Hitachi Storage Plug-in

Log in to the vSphere Client to confirm whether the plug-in you registered to the vCenter Server was successfully installed.

Procedure

1. Log in to the vSphere Client as a user assigned the Administrator role for vCenter Server.
2. In the navigation pane, select **Administration > Solutions > Client Plug-Ins**.
3. From the **Client Plug-Ins** list, make sure that **Hitachi Storage Plug-in** is enabled. After you enable **Hitachi Storage Plug-in**, it is also added to the **Menu** in vSphere Client.



Note:

- Specify settings so that the system time of the vCenter Server and the system time of the Backend Server are the same. To synchronize the Backend Server time with the NTP server time, specify settings for the NTP server on the ESXi server where the Backend Server is running. For more information, refer to VMware documentation (<https://www.vmware.com/support/pubs/>).
- If the cache of the vSphere Client browser still exists, the display of the plug-in window might not be correct. For this reason, after installation, delete the cache of the vSphere Client browser before you log in for the first time.
- After Hitachi Storage Plug-in is configured, if a connection to the Backend Server cannot be established, see [Troubleshooting when attempts to connect to the Backend Server fail \(on page 67\)](#).

Upgrading Hitachi Storage Plug-in

Software versions required for an upgrade

Upgrading Hitachi Storage Plug-in requires the following software versions, which are prerequisites for the upgrade.

Target	Software version
Backend Server	Hitachi Storage Plug-in 4.0.0 or above
vCenter Server	<p>For details, see Software requirements (on page 18).</p> <div style="background-color: #e0f2f1; padding: 10px; border: 1px solid #ccc;"> <p> Note: See Software requirements (on page 18) and check the vCenter Server version. If the version is not supported, upgrade the vCenter Server version, and then perform an overwrite installation of the plug-in.</p> </div>

 **Note:** If you are upgrading from Hitachi Storage Plug-in 4.9.2 or an earlier version, when using VSP One SDS Block v1.10 or an earlier version, you must also upgrade VSP One SDS Block to v1.12 or a later version. Perform the following procedure to upgrade.

1. Referring to [Removing a storage system \(on page 48\)](#), delete the registered VSP One SDS Block v1.10 or earlier version.
2. Upgrade Hitachi Storage Plug-in.
3. Upgrade VSP One SDS Block to v1.12 or a later version.
4. Referring to [Adding a VSP One SDS Block \(on page 47\)](#), register the upgraded VSP One SDS Block.

Upgrading Hitachi Storage Plug-in

To upgrade Hitachi Storage Plug-in, use either of the following methods:

- [Upgrading Hitachi Storage Plug-in by upgrading its files \(on page 29\)](#)

Upgrade the files related to the plug-in in the Backend Server environment you are using. This method requires fewer steps than the method whereby a new Backend Server is deployed and then upgraded. If you use this method, during the upgrade, you can back up files related to the plug-in and then restore the system to one of the last three versions.

- [Upgrading Hitachi Storage Plug-in by deploying a new Backend Server \(on page 31\)](#)

Deploy a new Backend Server, and then copy the plug-in configuration files and other files from the Backend Server you are currently using to the new Backend Server.

Upgrading Hitachi Storage Plug-in by upgrading its files

To upgrade Hitachi Storage Plug-in by upgrading the files related to the plug-in, perform the following procedure:

1. [Upgrading files related to the plug-in on the Backend Server \(on page 30\)](#)

2. [Upgrading the plug-in on the vCenter Server \(on page 33\)](#)
3. [Verifying installation of Hitachi Storage Plug-in \(on page 28\)](#)

Upgrading files related to the plug-in on the Backend Server

Upgrade the files related to the plug-in on the Backend Server.



Tip: The following configuration files are inherited as is after the upgrade.

Folder	File
/usr/local/hitachi-storage-plugin/	openssl.cnf
/usr/local/hitachi-storage-plugin/jetty/conf/	<ul style="list-style-type: none"> ▪ keystore.jks ▪ storageplugin.csr
/usr/local/hitachi-storage-plugin/jetty/webapps/conf/	<ul style="list-style-type: none"> ▪ HiStorageMgrConfig.xml ▪ hivcenter.config ▪ HNAS_multiaccount.xml ▪ log4j2.xml ▪ log_plugin-server.xml ▪ multiaccount.xml ▪ storage-info.json ▪ storage-plugin.properties ▪ vcenterList.json
/var/log/hitachi-storage-plugin/	<ul style="list-style-type: none"> ▪ PluginServer.log ▪ PluginServer.log.n ▪ spVmProps.log ▪ StoragePlugin.log ▪ StoragePlugin.log.n ▪ StoragePlugin_CreateCertification.log ▪ StoragePluginforBackendServerUpgrade.log ▪ StoragePluginforVMwarevCenter.log ▪ StoragePluginLog.tar.gz

Before you begin

Obtain the IP address and password of the Backend Server.

Procedure

1. Delete the browser cache of the browser used to access the vSphere Client.
2. Copy the `UpgradeFiles` directory on the installation media to the Backend Server. Copy the directory to a location of your choice.
3. Run the following script in the `UpgradeFiles` directory.

```
bash <copy-destination>/UpgradeFiles/Upgrade.sh
```

The files related to the plug-in are backed up and upgraded.

The files related to the plug-in are backed up to the following location by using the file name `backups_<version>`.

```
/var/backups/
```

You can back up a maximum of three generations of the files related to the plug-in. For example, if `backups_04.2.0`, `backups_04.3.0`, and `backups_04.4.0` already exist, when you upgrade version 4.5.0 to version 4.6.0, `backups_04.2.0` will be deleted, and `backups_04.5.0` will be created.

Upgrading Hitachi Storage Plug-in by deploying a new Backend Server

The following is the procedure for upgrading Hitachi Storage Plug-in by deploying a new Backend Server and copying the Hitachi Storage Plug-in configuration files, etc., from the Backend Server in use to the new Backend Server.

1. [Deploying a Backend Server \(on page 25\)](#)
Deploy the new version of the Backend Server.
2. [Migrating the configuration files from an older version of the Backend Server \(on page 31\)](#)
3. [Migrating the IP address of an older version of the Backend Server \(on page 32\)](#)
4. [Upgrading the plug-in on the vCenter Server \(on page 33\)](#)
5. [Deleting the Backend Server \(on page 36\)](#)
Delete the older version of the Backend Server.
6. [Verifying installation of Hitachi Storage Plug-in \(on page 28\)](#)



Note: If you do not need the new version to inherit the settings from the older version, skip steps 2 and 4.

Migrating the configuration files from an older version of the Backend Server

To migrate the configuration files from an older version of the Backend Server to a new version of the Backend Server, run a shell script on the new version of the Backend Server.

The following configuration files can be migrated.

Folder	File
/usr/local/hitachi-storage-plugin/jetty/webapps/conf	<ul style="list-style-type: none"> ▪ HiStorageMgrConfig.xml ▪ hivcenter.config ▪ HNAS_multiaccount.xml ▪ log4j2.xml ▪ log_plugin-server.xml ▪ multiaccount.xml ▪ storage-info.json ▪ storage-plugin.properties ▪ vcenterList.json
/var/log/hitachi-storage-plugin	<ul style="list-style-type: none"> ▪ PluginServer.log* ▪ PluginServer.log.n* ▪ StoragePlugin.log* ▪ StoragePlugin.log.n*
<p>* This file can be migrated only if the log file does not exist on the Backend Server that runs BackendServerUpgrade.sh.</p>	

Before you begin

- Obtain the IP address and password for the older version of the Backend Server.
- Start the older version of the Backend Server.

Procedure

1. Log in to the new version of the Backend Server as the root user.
Enter the root user password that was set in [Deploying a Backend Server \(on page 25\)](#).
2. Run the following shell script.

```
/usr/local/hitachi-storage-plugin/BackendServerUpgrade.sh <IP-address-of-the-older-version-of-the-Backend-Server> <password-of-the-older-version-of-the-Backend-Server>
```

If the password includes an exclamation point (!) followed by other characters, enclose the password in single quotation marks when you run the shell script.

Example: 'pass!word'

Migrating the IP address of an older version of the Backend Server

To use the IP address of an older version of the Backend Server for a new version of the Backend Server, change the settings from the vSphere Client.

Before you begin

Obtain the IP address of the older version of the Backend Server.

Procedure

1. Shut down the new and old versions of the Backend Server.
2. Follow the procedure in [Changing network information about the Backend Server \(on page 37\)](#) to change the IP address of the new version of the Backend Server to that of the old version.
3. Start the new version of the Backend Server.

Upgrading the plug-in on the vCenter Server

Run the shell script on a new version of the Backend Server to trigger the upgrade of Hitachi Storage Plug-in. This process pushes the new plug-in binary from the Backend Server to the vCenter Server where the plug-in is registered.

Before you begin**Obtain the following information:**

- The IP address, user name, and password of the vCenter Server
- The password of the vCenter Server Appliance root user

The vCenter Server user account must be assigned the Administrator role for vCenter Server.

Configure the BASH shell settings:

Configure the BASH shell settings for vCenter Server as explained in VMware product documentation (<https://kb.vmware.com/s/article/2100508>).

Procedure

1. Log in to the new version of the Backend Server as the root user.
Enter the root user password that was set in [Deploying a Backend Server \(on page 25\)](#).
2. Run the following shell script.

```
/usr/local/hitachi-storage-plugin/StoragePluginforVMwarevCenter.sh <IP-address-
of-vCenter-Server> <user-name-of-the-vCenter-Server> <password-of-the-vCenter-
Server> <password-of-the-vCenter-Server-Appliance-root-user> upgrade
```

If no default domain is set for the vCenter Server, specify a domain by adding the domain name to `<user-name-of-the-vCenter-Server>` (for example, `administrator@vsphere.local`).

If the password includes an exclamation point (!) followed by other characters, enclose the password in single quotation marks when you run the shell script.

Example: `'pass!word'`

**Note:**

Run this shell script for all vCenter Servers in the Hitachi Storage Plug-in instance. If the following error message appears, register the plug-in for the relevant vCenter Server. For details on how to register the plug-in, see [Running a shell script on the Backend Server \(registering the plug-in\) \(on page 27\)](#).

```
Hitachi Storage Plug-in was not registered.
```

Restoring Hitachi Storage Plug-in

You can restore the system to one of the last three versions only if Hitachi Storage Plug-in was upgraded by upgrading files.

To restore Hitachi Storage Plug-in, perform the following procedure:

1. [Copying backup files on the Backend Server \(on page 34\)](#)
2. [Running a shell script on the Backend Server \(unregistering the plug-in\) \(on page 35\)](#)
3. [Restarting the vSphere Client service in the vCenter Server \(on page 36\)](#)
4. [Running a shell script on the Backend Server \(registering the plug-in\) \(on page 27\)](#)
5. [Verifying installation of Hitachi Storage Plug-in \(on page 28\)](#)

Copying backup files on the Backend Server

Restore the files related to the plug-in by copying the files that were backed up on the Backend Server.

Before you begin

Obtain vCenter Server IP address, user name, and password.

Procedure

1. Log in to the Backend Server as a root user.
2. Run the following command to copy backup files.

```
rm -rf /usr/local/hitachi-storage-plugin/*
rm -f /etc/rc.d/init.d/plugin-server_sp
cd /var/backups/backups_<version>/
\cp -fpr hitachi-storage-plugin/* /usr/local/hitachi-storage-plugin/
\cp -fpr etc/rc.d/init.d/* /etc/rc.d/init.d/
```

**Note:**

- Run `rm -f /etc/rc.d/init.d/plugin-server_sp` only if you are restoring a Hitachi Storage Plug-in environment from version 4.9.0 or later to 4.8.0 or earlier.
- In `backups_<version>`, specify the directory of the version that you want to restore.

3. Run the following command to restart services on the Backend Server.

```
systemctl daemon-reload
systemctl restart jetty_sp
systemctl restart plugin-server_sp
```

Uninstalling Hitachi Storage Plug-in

Uninstall Hitachi Storage Plug-in by performing the following procedure:

1. [Running a shell script on the Backend Server \(unregistering the plug-in\) \(on page 35\)](#)
2. [Deleting the Backend Server \(on page 36\)](#)
3. [Verifying uninstallation of Hitachi Storage Plug-in \(on page 36\)](#)

Running a shell script on the Backend Server (unregistering the plug-in)

Run the shell script on the Backend Server to unregister the plug-in from the vCenter Server.

Before you begin

Obtain the following information:

- The IP address, user name, and password of the vCenter Server
- The password of the vCenter Server Appliance root user

The vCenter Server user account must have the Administrator role for vCenter Server.

Configure the BASH shell settings:

Configure the BASH shell settings for vCenter Server as explained in VMware product documentation (<https://kb.vmware.com/s/article/2100508>).

Procedure

1. Log in to the Backend Server as the root user.
2. Run the following shell script.

```
/usr/local/hitachi-storage-plugin/StoragePluginforVMwarevCenter.sh <IP-address-of-vCenter-Server> <user-name-of-the-vCenter-Server> <password-of-the-vCenter-Server> <password-of-the-vCenter-Server-Appliance-root-user> unregistration
```

If no default domain is set for the vCenter Server, specify a domain by adding the domain name to `<user-name-of-the-vCenter-Server>` (for example, `administrator@vsphere.local`).

If the password includes an exclamation point (!) followed by other characters, enclose the password in single quotation marks when you run the shell script.

Example: `'pass!word'`

**Note:**

Run this shell script for all vCenter Servers in the Hitachi Storage Plug-in instance. The following error message might appear, but continue running the shell script for all vCenter Servers.

```
Hitachi Storage Plug-in was not registered.
```

Deleting the Backend Server

If you no longer use the Backend Server, delete the virtual machine that is used as the Backend Server from the vSphere Client.

Procedure

1. If the Backend Server is running, shut it down.
2. On the vSphere Client, select the Backend Server in the list **Virtual Machines** and then select **Actions > Delete from Disk**.

Verifying uninstallation of Hitachi Storage Plug-in

Log in to the vSphere Client to confirm whether the plug-in was uninstalled from the vCenter Server.

Procedure

1. Restart the vSphere Client service.
For details about how to restart the vSphere Client service, see [Restarting the vSphere Client service in the vCenter Server \(on page 36\)](#).
2. Log in to the vSphere Client as a user assigned the Administrator role for vCenter Server.
3. In the list of **Client Plug-Ins** under **Administration**, make sure that **Hitachi Storage Plug-in** has been deleted. After you delete **Hitachi Storage Plug-in**, it is also deleted from the **Menu** in vSphere Client.
4. Manually delete the following roles:
 - Hitachi Storage Plug-in All Enable
 - Hitachi Storage Plug-in Read Only
 - Hitachi Storage Plug-in Without Deletion

For details about Role-Based Access Control, see [Role-Based Access Control \(on page 41\)](#).

Restarting the vSphere Client service in the vCenter Server

In the vCenter Server, you can restart the vSphere Client service.

Procedure

1. Log in as a root user to the vCenter Server.
2. Enter the following commands:

```
service-control --stop vsphere-ui
service-control --start vsphere-ui
```

Restarting services on the Backend Server

To enable configuration files, restart the services on the Backend Server.

Procedure

1. Log in to the Backend Server as the root user.
2. Run the following command on the Backend Server.

```
systemctl restart jetty_sp
systemctl restart plugin-server_sp
```

Changing network information about the Backend Server

You can change the following network information about the Backend Server:

- IP address
- Gateway
- Netmask

Before you begin

Verify the network information about the Backend Server that you want to change.

Procedure

1. If the Backend Server is running, shut it down.
2. From the navigator of vSphere Client, select the Backend Server, and then select **Configure > Settings > vApp Options**.
3. In **Properties**, select **Gateway**, **Netmask**, and **IP Address**, click **SET VALUE**, and then set a value.
4. Turn on the power of the Backend Server.
5. Unregister Hitachi Storage Plug-in, and then register it in the vCenter Server.

For details about how to unregister the plug-in, see [Running a shell script on the Backend Server \(unregistering the plug-in\) \(on page 35\)](#).

For details about how to register the plug-in, see [Running a shell script on the Backend Server \(registering the plug-in\) \(on page 27\)](#).



Caution: If you migrate the virtual machine that is used as the Backend Server to a different vCenter Server from the vCenter Server to which it was originally deployed, you will not be able to make changes in vApp Options. If this occurs, uninstall Hitachi Storage Plug-in and the Backend Server according to the procedure in [Uninstalling Hitachi Storage Plug-in \(on page 35\)](#), and then deploy the Backend Server again.

Changing the configuration files

By editing the configuration files, you can change the settings of the Backend Server log file and of LUN IDs. To change the settings of the Backend Server log file, edit the `log_plugin-server.xml` file or the `log4j2.xml` file. To change the settings of LUN IDs, edit the `hivcenter.config` file.



Note: If you change a configuration file, restart the service. See [Restarting services on the Backend Server \(on page 37\)](#).

Log file

Two types of log files on the Backend Server have changeable settings: `PluginServer.log` and `StoragePlugin.log`.

PluginServer.log

The results of communication between Hitachi Storage Plug-in running on VSphere Client and the Backend Server are output to the `PluginServer.log` file. To change the output settings of `PluginServer.log`, edit the `log_plugin-server.xml` file.

The `log_plugin-server.xml` file is stored in the following location:

```
/usr/local/hitachi-storage-plugin/jetty/webapps/conf
```

You can change the following settings:

Log file size

How to edit:

```
<maxFileSize><size></maxFileSize>
```

- Specify a unit (KB, MB, or GB) for `<size>`. For example, 10MB.
- Specify `<size>` by using single byte alphanumeric characters. Specify a decimal number.
- If the value is omitted, the default value (10MB) is used.
- If the value is invalid (the value is outside the valid range or contains a character other than a single-byte character), a connection to the Backend Server cannot be established and the Backend Server must be restarted.

Number of log generations

When the size of a log file exceeds the specified maximum size, the log file is renamed and saved with *.n* at the end. For example, `PluginServer.log` file will be renamed to `PluginServer.log.n`.

How to edit:

```
<minIndex><number-of-the-first-backup-file></minIndex>
<maxIndex><number-of-the-last-backup-file></maxIndex>
```

- Specify `<number-of-the-first-backup-file>` and `<number-of-the-last-backup-file>` in single-byte decimal numbers.
- If the value is omitted or an invalid value (a value other than a single-byte value) is used, the default value is used.
 - 1 is specified for `<number-of-the-first-backup-file>`.
 - 7 is specified for `<number-of-the-first-backup-file>`.

Log level

How to edit:

```
<Root level="<log-level>">
```

Specify one of the following for `<log-level>`:

- `info`: Outputs processing information, warnings, general errors, and fatal errors.
- `warn`: Outputs warnings, general errors, and fatal errors.
- `error`: Outputs general errors and fatal errors.
- `fatal`: Outputs fatal errors only.

If the value is omitted or an invalid value (a value outside the specifiable range) is used, the default value of `fatal` is used.

StoragePlugin.log

The following information is output to the `StoragePlugin.log` file.

- Information related to communication between the storage system and the Backend Server
- Information related to communication between vCenter Server and the Backend Server

Edit `log4j2.xml` file to change the settings log file (`StoragePlugin.log`).

The `log4j2.xml` file is stored in the following location:

```
/usr/local/hitachi-storage-plugin/jetty/webapps/conf
```

You can change the following settings:

Log file size**How to edit:**

```
<SizeBasedTriggeringPolicy size="<size>"/>
```

- Specify a unit (KB, MB, or GB) for *<size>*. For example, 10MB.
- Specify *<size>* by using single byte alphanumeric characters. Specify a decimal number.
- If the value is omitted or an invalid value (a value other than a single-byte value) is used, the default value of 10 MB is used.

Number of log generations

When the size of a log file exceeds the specified maximum size, the log file is renamed and saved with *.n* at the end. For example, `StoragePlugin.log` file will be renamed to `StoragePlugin.log.n`.

How to edit:

```
<DefaultRolloverStrategy max="<number-of-generations>"/>
```

- Specify *<number-of-generations>* in single-byte decimal numbers.
- If the value is omitted or an invalid value (a value other than a single-byte value) is used, the default value of 7 generations is used.

Log level**How to edit:**

```
<Root level="<log-level>">
```

Specify one of the following for *<log-level>*:

- `info`: Outputs processing information, warnings, general errors, and fatal errors.
- `warn`: Outputs warnings, general errors, and fatal errors.
- `error`: Outputs general errors and fatal errors.
- `fatal`: Outputs fatal errors only.

If the value is omitted or an invalid value (a value outside the specifiable range) is used, the default value of `error` is used.

LUN ID

On the Storage Configuration screen of the Provision Datastore wizard, you can specify LUN IDs. You can change the range of LUN IDs that can be specified on this screen by editing the `hivcenter.config` file to set the maximum and minimum values of the range.

The `hivcenter.config` file is stored in the following location:

```
/usr/local/hitachi-storage-plugin/jetty/webapps/conf
```



Note: If you are using NVMe over TCP connections in VSP One SDS Block, you cannot specify LUN IDs.

Edit the file with a text editor using alphanumeric characters. While editing this file, be sure to press <Enter> at the end of each line, including the file's final line (the file should end with a blank line).

- Specify values for `<minimum-LUN-ID>` and `<maximum-LUN-ID>` in `[MinLUNID=<minimum-LUN-ID>]` and `[MaxLUNID=<maximum-LUN-ID>]`, respectively.
- Specify values that are equal to or greater than 0.
- The maximum value that can be specified as a LUN ID for storage systems is different from that which can be specified for ESXi hosts. Be sure to check the specifications of the storage system or ESXi host that you are using.
- If no values are specified or an invalid value (a value outside the valid range, a value including a multi-byte character, or a minimum value that is greater than the maximum value) is specified, the default values of 0 and 1023 are used for the minimum value and maximum value, respectively.



Note: If you do not specify a value for LUN ID on the Storage Configuration screen of the Provision Datastore wizard, a value (which might be outside of the range defined by `<minimum-LUN-ID>` and `<maximum-LUN-ID>`) will be automatically assigned.

Role-Based Access Control

To use Hitachi Storage Plug-in, you must have the Administrator role for vCenter Server. However, if you install Hitachi Storage Plug-in, a role to be used exclusively by Hitachi Storage Plug-in will be created as a vCenter Server role. Using this role, you can also control the run permissions of Hitachi Storage Plug-in. By default, Role-Based Access Control is disabled.

Role in Hitachi Storage Plug-in	Operation	Execution permission
Hitachi Storage Plug-in All Enable	Viewing each screen	Yes
	Operations on storage systems ¹	Yes
	Operations on datastores ²	Yes
Hitachi Storage Plug-in Read Only	Viewing each screen	Yes
	Operations on storage systems ¹	Yes
	Operations on datastores ²	No

Role in Hitachi Storage Plug-in	Operation	Execution permission
Hitachi Storage Plug-in Without Deletion	Viewing each screen	Yes
	Operations on storage systems ¹	Yes
	Operations on datastores ²	Provision Datastore: Yes Expand Datastore: Yes Delete Datastore: No
<p>Notes:</p> <ol style="list-style-type: none"> 1. The following operations: Add Storage Systems, Refresh Storage Systems, and Remove Storage Systems 2. The following operations: Provision Datastore, Expand Datastore, and Delete Datastore 		

Setting up Role-Based Access Control

Enable Role-Based Access Control to control execution permissions for Hitachi Storage Plug-in users.

Procedure

1. Edit the `hivcenter.config` file and set the `SetRBAC` value to `TRUE`.

```
[SetRBAC=TRUE]
```



Note:

If you upgraded Hitachi Storage Plug-in from version 4.7.1 or an earlier version by performing the procedure in [Upgrading Hitachi Storage Plug-in by upgrading its files \(on page 29\)](#), the `hivcenter.config` file will not include the `SetRBAC` setting. Add `[SetRBAC=TRUE]` to the `hivcenter.config` file.

2. Access Hitachi Storage Plug-in.

For details on how to access Hitachi Storage Plug-in, see [Accessing Hitachi Storage Plug-in \(on page 45\)](#).

The user accessing Hitachi Storage Plug-in must be assigned a vCenter Server role with the **Modify role**.

When you access Hitachi Storage Plug-in, in the **Menu > Administration > Roles**, the following Hitachi Storage Plug-in roles will also be created:

- Hitachi Storage Plug-in All Enable
- Hitachi Storage Plug-in Read Only
- Hitachi Storage Plug-in Without Deletion



Note:

In an environment that includes multiple vCenter Servers for which Linked Mode is set, when you access Hitachi Storage Plug-in, roles are first created for the vCenter Server registered for Hitachi Storage Plug-in that you access. A few minutes later, roles will also be created for the other vCenter Servers. For this reason, if you want to access Hitachi Storage Plug-in registered for another vCenter Server, wait a few minutes before doing so.

If you access Hitachi Storage Plug-in before roles are created, duplicate roles might be created. In such cases, make sure that no users have been assigned the duplicate roles, and then delete one of the duplicate roles.

3. Assign Hitachi Storage Plug-in roles to users and groups.



Note:

- To assign a Hitachi Storage Plug-in role to a group, grant the target role the **Modify permission** permission.
- If a user is assigned to multiple roles, the role with the highest permission is given priority. The Hitachi Storage Plug-in role permissions in order of highest to lowest priority are: Hitachi Storage Plug-in All Enable (this role has the same level of priority as the Administrator role), Hitachi Storage Plug-in Without Deletion, and Hitachi Storage Plug-in Read Only.

Disabling the setting for Role-Based Access Control

To discontinue the control of execution permissions for Hitachi Storage Plug-in users, disable the setting for Role-Based Access Control.

Procedure

1. Edit the `hivcenter.config` file and set the `SetRBAC` value to `FALSE`.

```
[SetRBAC=FALSE]
```

Confirming the version of Hitachi Storage Plug-in

Log in to vSphere Client, and then confirm the version of Hitachi Storage Plug-in registered in vCenter Server.

Procedure

1. Access Hitachi Storage Plug-in.

For details on how to access Hitachi Storage Plug-in, see [Accessing Hitachi Storage Plug-in \(on page 45\)](#).

Access Hitachi Storage Plug-in as a user assigned the Administrator role for vCenter Server.

2. In vSphere Client, click **Menu**, and then click **Hitachi Storage Plug-in**.

There are several ways to access Hitachi Storage Plug-in. This procedure is one example.

3. Click the link of the instance for which the IP address of the Backend Server is displayed. The version appears.

Chapter 4: Using Hitachi Storage Plug-in

You can access Hitachi Storage Plug-in, add and remove storage systems, and perform storage provisioning operations from within the vSphere Client.

Accessing Hitachi Storage Plug-in

When Hitachi Storage Plug-in is installed, the Hitachi Storage Plug-in icon is added to the vSphere Client window.

Procedure

1. Log in to the vSphere Client from a browser.
2. In vSphere Client, click **Menu**, and then click **Hitachi Storage Plug-in**.

There are several ways to access Hitachi Storage Plug-in. This procedure is one example.



Note:

If you leave the Hitachi Storage Plug-in window displayed without performing any operation for a long time (30 minutes or more as a guide), log out of vSphere Client and log in again. If a window is left in this state for a long time, a session timeout occurs between the browser and vSphere Client, and the session information is discarded. Therefore, even if you use Hitachi Storage Plug-in to run a task such as **Add Storage Systems**, the task will not start although no error will occur.

Adding a storage system

Run the Add Storage Systems operation to register storage systems to be monitored by Hitachi Storage Plug-in. The registration procedure differs according to the type of storage system you want to add.

**Note:**

- To correctly display global-active device (GAD) volumes with Hitachi Storage Plug-in, you will need to use Hitachi Ops Center API Configuration Manager to manage both the primary storage system and the secondary storage system.
- If you are using VMware vCenter Server Appliance 8.0 (Update 1) or later and have never connected an ESXi host to the vCenter Server, you might not be able to successfully obtain the IP address of the vCenter Server, resulting in an error when adding storage systems. Before using Hitachi Storage Plug-in, connect an ESXi host to the vCenter Server.

Adding a block storage system

You can add storage systems of the following models as block storage systems: VSP E series, VSP F series, VSP G series, VSP N series, VSP 5000 series, and VSP One B20.

Procedure

1. In the **Storage Systems** window, click **Add Storage Systems**.
2. On **Type**, if you are using VSP E series, VSP F series, VSP G series, VSP N series, or VSP 5000 series, select **Hitachi Virtual Storage Platform family**, and if you are using VSP One B20, select **Hitachi Virtual Storage Platform One Block**, and then click **Next**.
3. On **Information**, enter the following information about the Hitachi Ops Center API Configuration Manager server or the REST API server for VSP One B20:
 - **IP Address**
Enter the IP address in IPv4 or IPv6 format. The maximum number of characters that can be used is 39.
 - **Port Number**
Enter the TCP port number (1 - 65536) used for communication between Hitachi Storage Plug-in and the Hitachi Ops Center API Configuration Manager server or the REST API server for VSP One B20. For VSP E series, VSP F series, VSP G series, VSP N series, and VSP 5000 series, the default value is 23451. For VSP One B20, the default value is 443.
 - **Use SSL**
Use SSL for communication between Hitachi Storage Plug-in and the Hitachi Ops Center API Configuration Manager server or the REST API server for VSP One B20. By default, the check box is selected. If the check box is not selected, for VSP E series, VSP F series, VSP G series, VSP N series, and VSP 5000 series, change the **Port Number** to 23450. For VSP One B20, change the **Port Number** to 80.
4. On **Physical Storage Discovery**, select all physical storage systems to be registered and all physical storage systems on which the VSMs that will be registered exist. (You can select multiple physical storage systems at the same time.)
Click **Next**.
5. On **Authorization**, enter the user ID and password for each of the selected physical storage systems as follows.

User ID	Password
<p>Enter the user ID (1 - 63 characters) of the target storage system. You can use alphanumeric characters and the following symbols.</p> <p>! # \$ % & ' * + - . / = ? @ ^ _ ` { } ~</p>	<p>Enter the password (6 - 63 characters) for the target storage system. You can use alphanumeric characters and the following ASCII symbols (which can be entered from a keyboard) excluding spaces.</p> <p>! # \$ % & ' () * + , - . / : ; < = > ? @ [\] ^ _ ` { } ~</p>

6. Click **Next**.
7. On **Virtual Storage Discovery**, select all physical storage systems and VSMs that will be registered. (You can select multiple physical storage systems and VSMs at the same time.)



Tip: The list of storage systems displays values acquired from the Hitachi Ops Center API Configuration Manager server or from the REST API server for VSP One B20.

8. On **Summary**, confirm the model and other information about the selected storage system.
9. Click **Finish**.



Note: If the connection fails (for example, a communication error occurs, the required storage systems are not displayed, or the user ID or password is incorrect), troubleshoot the issue or contact your storage system administrator to verify your user account.

Adding VSP One SDS Block

VSP One SDS Block multi-tenancy function

With the multi-tenancy function of VSP One SDS Block, by using the VPS administrator's credentials, you can create and delete volumes (datastores) in a pool associated with the tenant by registering the VPS managed by the administrator. You cannot browse or operate volumes (datastores) in pools other than those of the relevant tenant. Also, tenant administrators cannot view VSP One SDS Block hardware information (storage-node CPUs, memory, and ports). For details, see the *VSP One SDS Block Virtual Private Storage Administrator Guide*.

Adding a VSP One SDS Block

Procedure

1. In the **Storage System** window, click **Add Storage Systems**.
2. On **Type**, select **Hitachi Virtual Storage Platform One SDS Block**, and click **Next**.

3. On **Information**, enter the following information about a REST API server running on a VSP One SDS Block storage system:
 - **IP Address**
Enter the IP address in IPv4 format. The maximum number of characters that can be used is 15. Also, the following IP addresses cannot be used.
 - 0.0.0.0
 - 255.255.255.255
 - **Use SSL**
Use SSL for communication between Hitachi Storage Plug-in and the REST API server. By default, the check box is selected.
 - **Port Number**
Enter the port number (1 - 65536) used for communication with Hitachi Storage Plug-in and the REST API server. The default value is 443.
 - **User ID**
Enter the user ID (5 - 255 characters) used for communication with the REST API server for VSP One SDS Block. You can use alphanumeric characters and the following symbols.
! # \$ % & ' - . @ ^ _ ` { } ~
 - **Password**
Enter the password (1 - 256 characters) used for communication with the REST API server for VSP One SDS Block. You can use alphanumeric characters and the following symbols.
! " # \$ % & ' () * + , - . / : ; < = > ? @ [\] ^ _ ` { | } ~
4. In **Storage Discovery**, select the storage system (VSP One SDS Block) and VPS that you want to register. (You can select multiple VSP One SDS Blocks and VPS storage systems at the same time.)
5. On **Summary**, confirm the model and other information about the selected storage system.
6. Click **Finish**.



Note: If the connection fails (for example, a communication error occurs, the required storage systems are not displayed, or the user ID or password is incorrect), troubleshoot the issue or contact your storage system administrator to verify your user account.

Removing a storage system

Use Remove Storage Systems to remove a storage system from the monitoring target of Hitachi Storage Plug-in.



Note: Even if you remove storage systems by running Remove Storage Systems, datastores or LUs/volumes created by using Hitachi Storage Plug-in remain. If you want to remove those datastores or LUs/volumes, register the storage systems again, and then use [Deleting datastores \(on page 58\)](#).

Procedure

1. In the Navigator pane, click **Storage Systems**.
2. Select the storage system you want to remove from the **Storage Systems** list.
3. Right-click the storage system, and then click **Remove Storage Systems**.
4. Click **Yes**.

Refreshing storage system information

Run Refresh Storage Systems to update the information about all or selected storage systems.



Note:

- If you change the storage system configuration by using other tools, refresh the applicable storage system information before provisioning or deleting a datastore.
- If you re-install a VSP One SDS Block, refresh the storage system information before provisioning a datastore.

Refreshing all storage systems

When you navigate to the Storage Systems window, a dialog box appears and prompts you to refresh the information. This dialog box is displayed when the information needs to be refreshed for all registered storage systems. To get the latest storage system information, perform the following procedure.



Note: To refresh information about a single storage system, run Refresh Storage Systems from the Storage Systems list screen.

Procedure

1. When the dialog box appears, click **Yes**.
Information about all registered storage systems will be updated.
This processing takes time.
The progress of the refresh is shown in the **Recent Tasks** pane. The task to refresh storage system information is complete.
The Refresh Storage task completes.
2. To view the refreshed information, click the **Refresh** icon in the title bar of vSphere Client.

Refreshing selected storage systems

Refreshing storage systems from the Storage Systems list refreshes information about the selected storage systems.

Before you begin

Before refreshing a storage system, check whether any of the following settings for the user account specified to register the storage system have been changed:

- The password is changed.
- The account is removed.
- The View authority of the target storage system is removed from the account.

If any of these settings have been changed, delete the storage system and then register it again. Otherwise a task error message is displayed(*), and "N/A" might be displayed in some columns, such as the status column, in the storage system view. (* Task error messages are not displayed for VSP One SDS Block.)

Procedure

1. In the Hitachi Storage Plug-in navigator, click the **Storage Systems**.
2. Select the storage systems.
3. In the **Actions** drop down, choose **Refresh Storage Systems**.
4. In the verifying message, click **Yes**.
5. If a second confirmation message appears, click **OK**.
The progress of the refresh is shown in the **Recent Tasks** pane.
The Refresh Storage task completes.
6. Click the **Refresh** icon in the vSphere Client title bar to display the refreshed information.

Provisioning datastores

Running Provision Datastore enables you to create LUs or volumes for storage systems registered in Hitachi Storage Plug-in. You can use the created LUs or volumes as VMFS datastores, RDMs, or NFS datastores associated with LUs or volumes.



Note:

- You must have one of the following user roles:
 - Administrator
 - Hitachi Storage Plug-in All Enable
 - Hitachi Storage Plug-in Without Deletion
- You cannot use this function for the following datastores:
 - vVol datastores associated with vVol volumes
 - VMFS datastores associated with vVol volumes

Overview of Provision Datastore

Before you begin

Create the host group, iSCSI target, or NVMe over TCP target in which the WWN for the ESXi HBA is registered. If you do not create it, the host group, iSCSI target, or NVMe over TCP target will not appear on the selection screen.

An example of the host group used to assign the LU/volume:

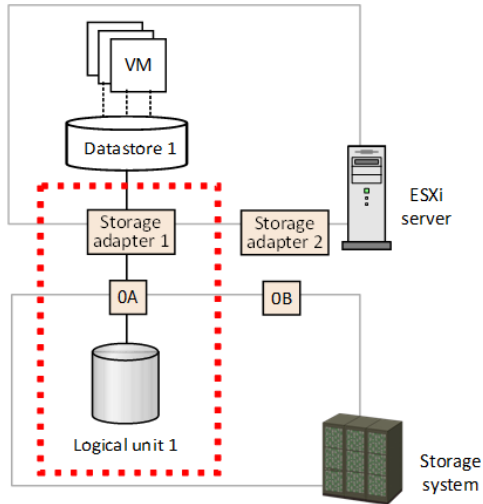

Legend:

..... : Host group 1

Example of host group: Logical unit and datastore are created in the Provision Datastore.

Host group 1	Name	BL360-B0-9
	Port	0A
	WWN	Storage adapter 1
	Logical unit	Logical unit 1

You can run Provision Datastore from the following screens:

- Storage Volumes list screen (Provision Datastore icon)
- Datastores list screen (Provision Datastore icon)
- Action menu on the Storage Systems Summary screen or another screen

Creating a datastore

This feature allows VMware datastores to be created, including the storage objects necessary to support them. Both VMFS and NFS datastores and Raw Device Mappings are supported.



Note: When registering compute node information on a VSP One SDS Block without using Hitachi Storage Plug-in, do not use a nickname that starts with `vCenterPlugin-`. Hitachi Storage Plug-in adds path information to the information about a compute node whose nickname starts with `vCenterPlugin-`.

Creating VMFS datastores

Before you begin

- Verify that all relevant ESXi hosts are connected to the storage system by a Fibre Channel or iSCSI connection.
- Choose a storage system upon which to create an LU/volume.
- Verify the DP pool that creates the LU/volume used in the VMFS datastore.
- Verify the host group, iSCSI target, or NVMe over TCP target of the storage system in which the WWN, iSCSI name, or host NQN of the storage adapter (ESXi HBA) is set.
- Make sure that the storage system information and vSphere environment information are current. If the information is not up to date, run Refresh Storage Systems.
- If you are using VSP One SDS Block and the same instance of vCenter Server is managing both storage nodes and compute nodes, do not select the storage adapter (Initiator) of an ESXi host that is being used as a storage node. The information about hosts that can be selected on the Storage Adapter screen includes information about ESXi hosts that are used as storage nodes.
- The number of storage adapters that can connect VSP One SDS Block storage systems (VSP One SDS Block and VPS) is the same as the number of storage adapters on the ESXi host. Also, for VSP One SDS Block storage systems, a single storage adapter can only connect a single VSP One SDS Block (system) or single VPS. If the storage adapter selected on the Storage Adapter screen of Provision Datastore is already dedicated to a VSP One SDS Block or VPS storage system, operations might fail.
- To use NVMe over TCP connections in VSP One SDS Block, you need the host NQN of ESXi. When you set a host name for Hostname of DNS Configuration for ESXi, you can set a host NQN. If no host name is set after ESXi is installed, `localhost` is set for Hostname. In this case, set a host name. If `localhost` remains set for Hostname, the Provision Datastore might not operate successfully.
- If Provision Datastore is run with VSP One B20 as the target, the created volume can only be a DRS volume.

Procedure

1. In the Hitachi Storage Plug-in navigator, click **Storage Volumes**.
2. Click the **Provision Datastore** icon to start the Provision Datastore.
3. On the **Type** screen, choose **VMFS Datastore**, then click **Next**.
4. On the **VMFS Version** screen, choose the VMFS version, then click **Next**.
5. On the **Name and Capacity** screen, perform the following steps:

To create a single datastore	To create multiple datastores
1. Select Single Datastore creation .	1. Choose Multiple Datastore creation .
2. Enter a name (3 - 42 characters) for the datastore. Acceptable characters: alphanumeric, space, ! # () + - , . = @ _	2. Enter a name (3 - 39 characters) for the datastore. Acceptable characters: alphanumeric, space, ! # () + - , . = @ _
3. Enter a value for the datastore capacity as allowed by the ESXi server you are using (2 - 65535 GB). The total capacity of the datastore is displayed on the Total column.	3. In Number of Datastores , enter the number of the datastores you want to create. You can create up to 256 datastores.
	4. For the Starting Number , enter a starting number (0 - 999) for the datastores. The datastore name is displayed on the Datastore Name column.
	5. In Datastore Capacity , enter a capacity value for each datastore (2 - 65535 GB). The total capacity of the datastore is displayed on the Total column.

6. Click **Next**.
7. On the **Storage Adapter** screen, select the storage adapter for the datastores.
 - a. From **Select Cluster or Host(s)**, select the cluster or ESXi host.
 - b. Select the storage adapter.
 - c. Click **Next**.
8. On the **Storage Configuration** screen, configure the storage system for the datastore(s).
 - a. Select **Storage Systems**.
 - For VSMS, the serial numbers for the VSMS and physical storage systems are displayed in **Storage Systems**.
`<Storage model>_<VSM serial number>(<Physical storage system serial number>)`
 - For VSP One SDS Block storage systems, the internal ID and nickname are also displayed in **Storage Systems**.
`<Storage model>_<Internal ID>_<Nickname>`
 - For VPS storage systems, the character string "VSSB" and the REST IP are also displayed in **Storage Systems**.
`VSSB_<VPS name>_<REST IP>`
 - b. Select **Pool / RAID Group**.

- c. Select **Capacity Saving** if you selected VSP E590, E790, E990, E1090, E590H, E790H, E1090H, VSP F350, F370, F700, F900, VSP G350, G370, G700, G900, VSP 5100, 5200, 5500, 5600, 5100H, 5200H, 5500H, 5600H, VSP One B20, or VSP One SDS Block.

**Note:**

Only the compression function can be used with VSP One SDS Block. If VPS is used, the setting for VPS volume capacity saving determines whether the compression function can be used.

- d. Specify a value for **LUN ID**.

You can specify this value if you selected **Single Datastore creation** on the **Name and Capacity** screen and selected a storage system that is managed by Hitachi Ops Center API Configuration Manager. You can specify a value in the range from 0 to 1023. If you do not specify a value for **LUN ID**, a value is automatically set.



Tip: To change the range of LUN IDs that can be specified, edit the `hivcenter.config` file. See [Changing the configuration files \(on page 38\)](#).



Note: If you are using NVMe over TCP connections in VSP One SDS Block, you cannot specify LUN IDs.

- e. If you select VSM for the **Storage Systems** in step a, the **Use LDEV ID from the resource group of selected Virtual Storage Machine** check box becomes active and can be selected. If you select a physical storage system for the **Storage Systems**, the check box cannot be selected.
- When the check box is not selected: An LDEV is created by using an LDEV ID that is reserved for meta_resource.
 - When the check box is selected: An LDEV is created by using an LDEV ID that is reserved for a resource group within the VSM.
- f. Select **Host Group/Target**.
- g. Click **Next**.

9. On the **Summary** screen, confirm the settings for the datastore. Click a screen name to modify any settings.
10. Click **Finish**. The datastore creation progress and results can be viewed in the **Recent Tasks** of the vSphere Client.



Note: You can cancel the Provision Datastore after the datastore creation process starts; however, rollback is not enabled. Any LUs/volumes already created will remain on the storage system and must be deleted manually.

Creating LUs/volumes for Raw Device Mapping(RDM)

Before you begin

- Make sure that the storage adapter (ESXi HBA) is connected to the storage system.
- Choose the storage system for creating the LU/volume used for RDM.

- Verify the DP pool that creates the LU/volume used for RDM.
- Verify the host group, iSCSI target, or NVMe over TCP target of the storage system in which the WWN, iSCSI name, or host NQN of the storage adapter (ESXi HBA) is set.
- Make sure that the storage system information and vSphere environment information are current. If the information is not up to date, run Refresh Storage Systems.
- If you are using VSP One SDS Block and the same instance of vCenter Server is managing both storage nodes and compute nodes, do not select the storage adapter (Initiator) of an ESXi host that is being used as a storage node. The information about hosts that can be selected on Storage Adapter screen includes information about ESXi hosts that are used as storage nodes.
- The number of storage adapters that can connect VSP One SDS Block storage systems (VSP One SDS Block and VPS) is the same as the number of storage adapters on the ESXi host. Also, for VSP One SDS Block storage systems, a single storage adapter can only connect a single VSP One SDS Block (system) or single VPS. If the storage adapter selected on the Storage Adapter screen of Provision Datastore is already dedicated to a VSP One SDS Block or VPS storage system, operations might fail.
- To use NVMe over TCP connections in VSP One SDS Block, you need the host NQN of ESXi. When you set a host name for Hostname of DNS Configuration for ESXi, you can set a host NQN. If no host name is set after ESXi is installed, `localhost` is set for Hostname. In this case, set a host name. If `localhost` remains set for Hostname, the Provision Datastore might not operate successfully.
- If Provision Datastore is run with VSP One B20 as the target, the created volume can only be a DRS volume.

Procedure

1. In the Hitachi Storage Plug-in navigator, click **Storage Volumes**.
2. Click the **Provision Datastore** icon to start the Provision Datastore.
3. On the **Type** screen, select **Volume for Raw Device Mapping**, click **Next**.
4. On the **Capacity** screen, perform the following steps:

For Single Volume creation	For Multiple Volume creation
1. Choose Single Volume creation .	1. Choose Multiple Volume creation .
2. Enter a value for the volume capacity (2 GB-65,535 GB).	2. Enter the number of volumes (256 maximum) you want to create.
3. Click Next .	3. Enter a capacity value for each volume (2-65,535 GB). The total capacity for the multiple volume is displayed on the Total .
	4. Click Next .

5. On the **Storage Adapter** screen, select the storage adapter for the LUs/volumes.
 - a. From **Select Cluster or Host(s)**, select the cluster or ESXi host on which the LUs/volumes are to be created.

- b. Select the storage adapter for the LUs/volumes.
 - c. Click **Next**.
6. On the **Storage Configuration** screen, configure the storage system for the LUs/volumes.
- a. Select **Storage Systems**.
 - For VSMS, the serial numbers for the VSMS and physical storage systems are displayed in **Storage Systems**.

```
<Storage model>_<VSM serial number>( <Physical storage system serial number>)
```
 - For VSP One SDS Block storage systems, the internal ID and nickname are also displayed in **Storage Systems**.

```
<Storage model>_<Internal ID>_<Nickname>
```
 - For VPS storage systems, the character string "VSSB" and the REST IP are also displayed in **Storage Systems**.

```
VSSB_<VPS name>_<REST IP>
```
 - b. Select **Pool / RAID Group**.
 - c. Select **Capacity Saving** if you selected VSP E590, E790, E990, E1090, E590H, E790H, E1090H, VSP F350, F370, F700, F900, VSP G350, G370, G700, G900, VSP 5100, 5200, 5500, 5600, 5100H, 5200H, 5500H, 5600H, VSP One B20, or VSP One SDS Block.

**Note:**

Only the compression function can be used with VSP One SDS Block. If VPS is used, the setting for VPS volume capacity saving determines whether the compression function can be used.

- d. Specify a value for **LUN ID**.
You can specify this item if you selected **Single Volume creation** on the **Capacity** screen and selected a storage system that is managed by Hitachi Ops Center API Configuration Manager. You can specify a value in the range from 0 to 1023. If you do not specify a value for **LUN ID**, a value will be automatically set.



Tip: To change the range of LUN IDs that can be specified, edit the `hivcenter.config` file. See [Changing the configuration files \(on page 38\)](#).



Note: If you are using NVMe over TCP connections in VSP One SDS Block, you cannot specify LUN IDs.

- e. If you selected a VSM for **Storage Systems** in step a, the **Use LDEV ID from the resource group of selected Virtual Storage Machine** check box is activated and

can be selected. If you selected a physical storage system for **Storage Systems**, the check box cannot be selected.

- When the check box is not selected: An LDEV is created by using an LDEV ID that is reserved for meta_resource.
- When the check box is selected: An LDEV is created by using an LDEV ID that is reserved for a resource group within the VSM.

f. Select **Host Group/Target**.

g. Click **Next**.

7. On the **Summary** screen, confirm the settings for the LUs/volumes. Click a screen name to modify any settings.
8. Click **Finish**. The datastore creation progress and results can be viewed in the **Recent Tasks** pane of the vSphere Client.



Note: You can cancel the LU/volume creation process after the datastore creation process starts; however, any LUs/volumes already created remain on the storage system and must be deleted manually. Delete them manually by running **Delete Datastore**. Contact your storage system administrator for additional assistance.

Cancelling Provision Datastore

You can cancel Provision Datastore after the datastore creation process is started, however, rollback is not enabled. Any LUs/volumes already created remain on the storage system and must be deleted manually.

Procedure

1. Click **Refresh Storage Systems**.
2. Click **Delete Datastore**, then manually delete any LUs/volumes remaining on the storage system. See [Deleting datastores \(on page 58\)](#) or ask the storage administrator for deletion of volume ID output in the message.
3. Verify that all LUs/volumes have been deleted.

Expanding a datastore

Using the Expand Datastore feature, you can expand the capacity of an existing datastore. You can expand a volume that backs up a VMFS datastore on an ESXi host, and expand the datastore capacity to the maximum capacity of the volume.

Before you begin

- The volume that backs up a VMFS datastore on an ESXi host must be a volume from a block storage system or a volume of a VSP One SDS Block.
- You must have one of the following user roles:
 - Administrator
 - Hitachi Storage Plug-in All Enable
 - Hitachi Storage Plug-in Without Deletion
- You cannot use this function for the following datastores:
 - vVol datastores associated with vVol volumes
 - VMFS datastores associated with vVol volumes

Procedure

1. In the Hitachi Storage Plug-in window, click **Datastores**.
2. Perform one of the following steps:
 - Right-click the datastore that you want to expand, and then select **Expand Datastore**.
 - Select the datastore that you want to expand, go to the **Summary** tab, and select **Actions > Hitachi Storage Plug-in > Expand Datastore**.
3. In **Storage Configuration**, enter the size by which you want to expand the volume. If you specify 0, the volume is not expanded, but the datastore is expanded to the maximum capacity of the volume if the datastore capacity does not already match the maximum capacity of the volume.
4. In the **Summary**, confirm the settings for the datastore. To modify settings, click **Back** and then modify the required settings.
5. Click **Finish**.



Note: If the expansion fails, the volume's status becomes `ExpansionFailed`. If you perform expansion again for the same volume, the value you entered for **Storage Configuration** is ignored, and the volume is expanded based on the value that was set when expansion failed.

Deleting datastores

Running Delete Datastore enables you to delete datastores/LUs/volumes on storage systems that are registered by using Hitachi Storage Plug-in.

To run Delete Datastore, you must have one of the following user roles:

- Administrator
- Hitachi Storage Plug-in All Enable

The following datastores cannot be deleted by using Delete Datastore:

- vVol datastores associated with vVol volumes
- VMFS datastores associated with vVol volumes
- Datastores with a virtual machine or virtual machine template
- Datastores with multiple LUs/volumes
- Datastores with pair-configured LUs/volumes
- Datastores with LUs/volumes used in a Raw Device Mapping (RDM)

If you cannot delete a datastore, ask your storage administrator to delete it.



Note: If a VSP One SDS Block is used, compute node information cannot be deleted in Hitachi Storage Plug-in. To delete compute node information, use the storage system API or another method.

Deleting a VMFS datastore/LU/volume

You can delete the VMFS datastores/LUs/volumes that are registered in Hitachi Storage Plug-in on storage systems.



Caution: Even after datastores/LUs/volumes that were created by selecting Deduplication And Compression have been deleted from the Hitachi Storage Plug-in screen, it might take some time before the LUs/volumes in the storage system are completely deleted. After the deletion, it might take time before free space in the pool increases.

Before you begin

Make sure that the storage system information and vSphere environment information are up to date. If the information is not up to date, run Refresh Storage Systems.

Procedure

1. In the Hitachi Storage Plug-in window, click **Storage Volumes**, or **Datastores**.
2. Select the datastore/LU/volume you want to delete. You can delete multiple datastores at a time.
3. Right-click and select **Delete Datastore**.
4. Click **Yes** to confirm deletion.



Note: To cancel the task, click **Cancel**. When you cancel **Delete Datastore**, the LUN that is not deleted remains. Delete unnecessary LUNs.

The results of the **Delete Datastore** appear in the vSphere Client task. When you click the **Refresh** icon, the **Recent Tasks** pane displays the Delete Datastore task.

Deleting an NFS datastore

Before you begin

Make sure that the storage system information and vSphere environment information are up to date. If the information is not up to date, run Refresh Storage Systems.

Procedure

1. On the Hitachi Storage Plug-in window, Click **Storage Volumes**.
2. Select the datastore you want to delete. You can delete only one datastore at a time.
3. Right-click and select **Delete Datastore**.
4. Click **Yes** to confirm deletion.

The results of the **Delete Datastore** appear in the vSphere Client task. When you click the **Refresh** icon, the **Recent Tasks** pane displays the Delete Datastore task.

Chapter 5: Information Display

Hitachi Storage Plug-in displays Hitachi storage system information in the vSphere Client. This information includes views of storage system properties and related objects. It also lists storage nodes, storage volumes, ESXi hosts, datastores, and virtual machines.

Datastore information

After registering the storage system with Hitachi Storage Plug-in, the datastores associated with that storage system are displayed.

If you select a datastore from the list, the datastore configuration objects appear in the Summary tab.

For example, if a datastore is backed by an LU or a volume, information identifying the LU's/volume's storage system and volume will appear in the Summary tab.

Host information

The Hosts screen displays the ESXi hosted registered storage system in Hitachi Storage Plug-in.

After registering the storage system with Hitachi Storage Plug-in, ESXi hosts (that consume resources from this storage system) appear on the Hosts screen.

When an ESXi host is selected, information about the storage systems associated with the selected ESXi host appears on the Summary tab.

Virtual Machines information

The Virtual Machines list displays the virtual machines list of the registered datastores in Hitachi Storage Plug-in.

After registering the storage system with Hitachi Storage Plug-in, virtual machines (that consume resources from this storage system) appear on the Virtual Machines information screen.

If you select a virtual machine from the list, storage system configuration objects associated with the virtual machine appear on the Summary tab.

For example, if a virtual machine resides on a VMFS file system backed by an LU or a volume, information identifying the LU's/volume's storage system and volume will appear in the Summary tab.

Chapter 6: Troubleshooting

Troubleshooting Hitachi Storage Plug-in installation

If a problem occurs during the installation of Hitachi Storage Plug-in, an error message is displayed. Follow the error message for further directions.

If you cannot identify the problem, review the troubleshooting information.

Troubleshooting Hitachi Storage Plug-in operational errors

If problems occur while using Hitachi Storage Plug-in, error information is displayed and output to a log file. Follow the error message for further directions.

If you cannot identify the problem, verify the following:

- All requirements are met.
- Review the operating environment and [Troubleshooting storage system errors \(on page 62\)](#) topic.



Note: If you are using Hitachi Ops Center API Configuration Manager, the status of the task to refresh configuration information might not be "Succeeded". To check the status of the task to refresh the configuration information about a storage system managed by Hitachi Ops Center API Configuration Manager, contact your storage system administrator.

If none of the above solves the problem, contact customer support.

Troubleshooting storage system errors

When errors occur within a storage system, the errors might also appear in the logs of components such as Hitachi Ops Center API Configuration Manager, vCenter Server, or ESXi.

The following procedures explain how to investigate storage system errors.

Procedure

1. Check the storage system environment.
Confirm that the storage system is online and healthy.

Also, confirm that the storage system requirements are fulfilled, and that the storage system's configuration complies with what's described in [Restrictions and considerations \(on page 21\)](#). Even if these requirements were met at the time Hitachi Storage Plug-in was installed, changes to the storage system made thereafter may have yielded an unsupported configuration.
2. Confirm Ethernet connections.
Confirm that the storage system is attached to the LAN with a network cable.
3. Confirm the IP address.
Confirm that the IP address being used to access the storage system matches the IP address displayed in its management interface.
4. Confirm the TCP port number.
Verify that the TCP port number used to access the storage system has not changed.

If the TCP port number has changed, add `df-damp-snm <storage system port number>/tcp` to the VMware management client's Services file.
5. Confirm firewall settings.
Verify that the storage system's accessible using TCP/IP. Depending on specifics which will vary between environments, it may be necessary to adjust firewall settings to allow this access.
6. Confirm ESXi connectivity.
Verify the following:
 - a. Whether Fibre Channel and TCP/IP connectivity between the ESXi host and the storage system is healthy.
 - b. Whether LU/volume masking is configured correctly on the storage system. For Fibre Channel access, LU/volume masking is represented by host group objects. For iSCSI access, it is represented by iSCSI target objects. For NVMe over TCP access, it is represented by NVMe over TCP target objects.

Troubleshooting Hitachi Ops Center API Configuration Manager server errors

If a problem occurs while you are using Hitachi Storage Plug-in, a failure might have occurred on the Hitachi Ops Center API Configuration Manager server. Perform the following procedure to check the status of the Hitachi Ops Center API Configuration Manager server:

Procedure

1. Confirm items of the Hitachi Ops Center API Configuration Manager server environment.
Verify that the Hitachi Ops Center API Configuration Manager server started without problems. Also, verify that the Hitachi Ops Center API Configuration Manager service has not stopped.

2. Confirm TCP/IP connectivity.
Verify that the Hitachi Ops Center API Configuration Manager server is attached to the LAN with a network cable.
3. Confirm the IP address.
Verify that the IP address used to access Hitachi Ops Center API Configuration Manager matches the IP address it's configured to use.
4. Confirm the TCP port number.
Verify that the TCP port number used for the Hitachi Ops Center API Configuration Manager server is correct. Register the new number if the TCP port number is different.
5. Confirm firewall settings.
Verify that Hitachi Ops Center API Configuration Manager is accessible using TCP/IP.
If it's inaccessible, a firewall configuration change may be required to allow access.
6. Resources managed by Hitachi Ops Center API Configuration Manager.
 - a. Ensure that the desired storage system is registered with Hitachi Ops Center API Configuration Manager.
 - b. If a resource group lock is preventing Hitachi Ops Center API Configuration Manager from collecting information from the storage system, it may be necessary to remove the lock.
 - c. Verify that Hitachi Ops Center API Configuration Manager is able to retrieve information from and configure the storage system.
 - d. Verify that the storage system information gotten by Hitachi Ops Center API Configuration Manager is consistent with the information displayed using more low-level Hitachi management interfaces, such as Storage Navigator or CCI.
7. Confirm the storage system user account.
 - a. Verify that the storage system account is valid and enabled.
 - b. Verify that the storage system account password is correct.
 - c. Verify that the storage system account is configured with view and modify permissions.

Troubleshooting errors related to the datastore creation function

Retry of Provision Datastore

LUs/volumes created by the Provision Datastore may not appear immediately in vSphere Client. If they do not appear, run Refresh Storage Systems.

It may also be necessary to run Refresh Storage Systems after using the Provision Datastore, before newly created storage objects will appear in vSphere Client's Storage Volumes list.

Procedure

1. Verify the failure message shown in the **Recent Tasks**.

2. In the Hitachi Storage Plug-in navigator, click **Storage Volumes**.
3. Click the **Provision Datastore** icon to start the Provision Datastore.
4. Click **Yes** on the warning message.
The Provision Datastore task on the Recent Tasks pane will be marked complete when the retry is finished.
5. **Refresh** the storage system.

Rollback of Provision Datastore

Procedure

1. Verify the failure message shown in **Recent Tasks** when Provision Datastore fails.
2. In the Hitachi Storage Plug-in navigator, click **Storage Volumes**.
3. Click the **Provision Datastore** icon to start the Provision Datastore.
4. Click **No** on the warning.
5. Click **Yes** on the next warning message to continue the rollback of **Provision Datastore**.
6. Click the **Refresh** icon to display the rollback progress status on the **Recent tasks**.
Once Recent Tasks has been refreshed, the task should appear to have been completed.



Note: The information displayed in **Recent Tasks** may not update itself automatically. To update Recent Tasks, click the **Refresh** icon.

Provision Datastore task stops before completing

If you did not run Retry or Rollback, the created LUs/volumes remain on the server. Verify the following:

If the task stops while creating storage system LUs/volumes.

1. Display the event of the task.
2. Delete the storage system LU/volume created by the partially completed task.
3. Run Refresh Storage Systems to retrieve the latest information.

If the task stops after creating an LU/volume, yet before performing target LU/volume masking (the host group operation), or if the task stops after LU/volume masking and before ESXi has detected the LU/volume.

1. Display the event task.
2. Remove the LU/volume created by the task that failed to complete from the host group object, if applicable.
3. Delete the LU/volume created by the incomplete task.
4. Run Refresh Storage Systems to retrieve the latest information.

If the task stops during datastore creation.

1. Run Refresh Storage Systems to retrieve the latest information.
2. Delete the LU/volume by running Delete Datastore.

3. Run Refresh Storage Systems a second time to ensure that the latest information is displayed.

Stops while retrying NFS Export Creation

Procedure

1. Views the task event.
2. Report the error message to customer support.
3. Run **Refresh Storage Systems**.

Stops while creating an NFS datastore

Procedure

1. Refresh the storage system.
2. Report the error message for customer support.
3. Run **Refresh Storage Systems** again.

Troubleshooting errors related to the datastore deletion function

This section describes how to retry Delete Datastore operations and how to recover when Delete Datastore stops prematurely.

Retry of Delete Datastore

Procedure

1. View the error message shown in the **Recent Tasks** pane.
2. In the Hitachi Storage Plug-in navigator, click **Storage Volumes**.
3. Select the datastore/LU/volume that you want to delete. Right-click and select **Delete Datastore**.
4. Click **Yes** on the warning message.
5. Watch **Recent Tasks** to observe the **Delete Datastore** task. If the **Delete Datastore** operation succeeds, it appears in **Recent Tasks** as complete.
6. Run **Refresh Storage Systems** after running **Delete Datastore**.

Delete Datastore stops before it has completed

If the vSphere Client service stops while a Delete Datastore task is running, it may leave a partial storage configuration in place. These procedures describe how to recover from this situation.

If the task stops during the confirmation of LU/volume usage status or datastore deletion.

1. Run Refresh Storage Systems to retrieve the latest information.
2. Observe the Datastores list to determine whether the LU/volume being deleted remains in the list. If it remains, try Delete Datastore again.
3. Run Refresh Storage Systems to retrieve the latest information.

If the task stops while unmapping or deleting the LU/volume.

1. Verify that the LU/volume has been deleted from the storage system.
2. Run Refresh Storage Systems to retrieve the latest information.

Troubleshooting when attempts to connect to the Backend Server fail

If the SSL certificate has been changed, attempts to connect to the Backend Server might fail. In such cases, perform the following procedure to run a shell script.

Before you begin

Obtain the following information:

- The IP address, user name, and password of the vCenter Server
- The password of the vCenter Server Appliance root user

The vCenter Server user account must have the Administrator role for vCenter Server.

Configure the BASH shell settings:

Configure the BASH shell settings for vCenter Server as explained in VMware product documentation (<https://kb.vmware.com/s/article/2100508>).

Procedure

1. Log in to the Backend Server as the root user.
Enter the root user password that was set in [Deploying a Backend Server \(on page 25\)](#).
2. Run the following shell script.

```
/usr/local/hitachi-storage-plugin/PluginServerUpdate.sh <IP-address-of-vCenter-Server> <password-of-the-vCenter-Server-Appliance-root-user>
```

If the password includes an exclamation point (!) followed by other characters, enclose the password in single quotation marks when you run the shell script.

Example: 'pass!word'

Chapter 7: Information to collect when a failure occurs

If a failure occurs, in addition to the logs of Hitachi Storage Plug-in, you must also collect the logs and version information of related products. The following explains how to collect this information. If the problem persists even after troubleshooting, collect the various types of information as described in this section and then contact customer support.

Collecting log files

Collect log files of Hitachi Storage Plug-in as well as information about related products.

Collecting log files from Hitachi Storage Plug-in

You can collect the Hitachi Storage Plug-in files from the vCenter Server, the Backend Server, and the ESXi host, and then archive the collected files into a tar.gz file.

Before you begin

- Check the IP address of the vCenter Server from which you want to collect the log files and the password of the root user of vCenter Server Appliance. If you want to collect log files from multiple vCenter Servers, check the IP addresses of all vCenter Servers from which you want to collect log files, as well as the password of the root user of vCenter Server Appliance. If a Linked Mode group is configured on the vCenter Servers, check the IP addresses and root user password for all vCenter Servers in the group.
- Configure the BASH shell settings for vCenter Server as explained in VMware product documentation (<https://kb.vmware.com/s/article/2100508>).

Procedure

1. Log in to the Backend Server as the root user. Use the `GetLog.sh` script to collect the Backend Server and vCenter Server log files.

Syntax

```
/usr/local/hitachi-storage-plugin/GetLog.sh <IP-address-of-vCenter-Server>  
<password-of-the-vCenter-Server-Appliance-root-user>
```

If the password includes an exclamation point (!) followed by other characters, enclose the password in single quotation marks when you run the shell script.

Example: 'pass!word'

Output-destination directory

/var/log/hitachi-storage-plugin

Archive file

StoragePluginLog.tar.gz

The following files and directories are collected by GetLog.sh:

- vCenter Server:

Directory: /storage/log/vmware/vsphere-ui/logs/

All files and all subdirectories stored in this directory are collected.

- Backend Server:

Directory	File
/usr/local/hitachi-storage-plugin/jetty/webapps/	version.txt
/usr/local/hitachi-storage-plugin/jetty/webapps/conf/	<ul style="list-style-type: none"> ■ HiStorageMgrConfig.xml ■ hivcenter.config ■ HNAS_multiaccount.xml ■ log4j2.xml ■ log_plugin-server.xml ■ multiaccount.xml ■ vcenterList.json
/var/log/hitachi-storage-plugin/	<ul style="list-style-type: none"> ■ PluginServer.log ■ PluginServer.log.n ■ spVmProps.log ■ StoragePlugin.log ■ StoragePlugin.log.n ■ StoragePlugin_CreateCertification.log ■ StoragePluginforBackendServerUpgrade.log ■ StoragePluginforVMwarevCenter.log
/var/log/	<ul style="list-style-type: none"> ■ messages ■ messages-YYYYMMDD

**Note:**

- If a failure occurs in communication with the vCenter Server, an error message is displayed and the `GetLog.sh` script ends.
 - If you run the `GetLog.sh` script with no argument specified, only the Backend Server log file will be collected.
2. If there are multiple vCenter Servers on which Hitachi Storage Plug-in is registered, enter `yes` to collect the log files from the next vCenter Server and then specify the IP address of the next vCenter Server and the password of the root user of vCenter Server Appliance as arguments. Repeat this process for each vCenter Server. If you use a Linked Mode group, collect the log files from all vCenter Servers in the group.
 - If you have only one vCenter Server, or if you finish collecting log files from multiple vCenter servers, enter `no` to end the processing.
2. Log in to the ESXi host, and manually collect the log files. Collect the files in the following directory.
 - Directory: `/var/log/`
 - File:
 - `vpxa.log`
 - `vmkernel.log`
 3. Archive the collected files into a `tar.gz` file.

**Note:**

Before sending the log files to customer support, check the files to make sure that they do not contain any security-related information, such as passwords.

Collecting vCenter Server Appliance information

Collect the Support Bundle. For example, from the vCenter Server Appliance Management Interface, run `Actions > Create Support Bundle`.



Note: See the VMware vCenter Server documentation for steps to create a VMware Support Bundle.

How to collect Hitachi Ops Center API Configuration Manager information

To investigate a failure, in addition to Hitachi Storage Plug-in maintenance information, you also need to collect maintenance information about Hitachi Ops Center API Configuration Manager and about storage systems.

Collecting Hitachi Ops Center API Configuration Manager maintenance information

Hitachi Ops Center API Configuration Manager includes a feature to collect the maintenance information. For more details, see the *Hitachi Ops Center API Configuration Manager REST API Reference Guide*.

Collecting storage system information

If you are using an SVP, collect the normal dump files. If you are not using an SVP, collect system dumps by using the maintenance utility.

For details, refer to the *Hitachi Ops Center API Configuration Manager REST API Reference Guide* and check the correct dump types and prerequisites.

For details about how to collect the dump files of storage systems, see the *System Administrator Guide*.

Collecting Windows Event Log information

Procedure

1. Open Windows **Event Viewer**.
2. In **Event Viewer**, right click on the event log category (at least Application and System), and click **Save All Events As**.
3. Input a file name for the export file in the **File name** box.
4. Click the appropriate file format in the **File type** box, click **Save**.

Collecting Windows system information

Procedure

1. Open Microsoft System Information.
If an icon for this does not appear in Administrative Tools, it can be started from a cmd or PowerShell command prompt by entering `msinfo32`.
2. Click **Export** from the **File** menu.
3. Input the file name in the **File name** field.
4. Click **Save**.

Confirming versions

Confirming the vCenter Server version

Procedure

1. From the **home** screen of vSphere Client, select **Hosts and Clusters**.

2. From the tree view, select vCenter Server, and then confirm the version displayed in **Summary** screen.

Confirming the ESXi version

Procedure

1. From the **home** screen of vSphere Client, select **Hosts and Clusters**.
2. From the tree view, select ESXi, and then confirm the version displayed in **Summary** screen.

Checking the browser information about vSphere Client

Check the browser and the browser version used for vSphere Client.

Confirming the vSphere Client version

Procedure

1. Click the  icon at the top of vSphere Client, and then click **About VMware vSphere**.
2. From the displayed dialog box, confirm the vSphere Client version.

Hitachi Vantara



Corporate Headquarters
2535 Augustine Drive
Santa Clara, CA 95054 USA

HitachiVantara.com/contact